

Mathematics Mastery

10-week maths pack

Guidance on using these resources:

We have mapped out ten weeks of activities consisting of four sessions in each week.

Each session is designed to last 1 hour and consists of:

- Two tasks contained within this pack (20 minutes)
- A practice exercise linked to the tasks contained in the exercise pack (40 minutes)

The focus for each of the weeks and the session titles are shown in the timetable on the next page

How can I check my answers are correct?

We will be releasing full answers to this booklet and the practice exercises within the next week

Can parents, carers and siblings help?

Yes of course! They can help you by working through the tasks together and being someone to talk about the maths with. They can also help you check your work once you are finished each session.

	Session title	Learning outcome
Week 1: Transformations	Translation	Translate a shape by a given vector
	Rotation	Rotate a shape around a point of rotation
	Reflection	Reflect a shape in a line of reflection
	Isometries	Recognise transformations that conserve shape dimensions
Week 2: More transformations	Combining reflections	Find the resulting transformation when reflections are combined
	Combining translations and reflections	Look at the effect for combining translations and reflections in different orders
	Enlargements	Enlarge a shape by a given scale factor
	Enlargement and area	Look at how area is affected by an enlargement
Week 3: Prime factorisation 1	Indices	Use index notation
	Prime factors	Find the prime factors of a number
	Prime factorisation	Write a number as a product of prime factors
	Using the prime factorisation	Use the prime factorisation to recognise properties of numbers
Week 4: Prime factorisation 2	Highest common factor	Find the highest common factor of two numbers
	More highest common factor	Compare strategies for finding the highest common factor
	Lowest common multiple	Find the lowest common multiple of two numbers
	More lowest common multiple	Compare strategies for finding the lowest common multiple
Week 5: Fractions	Part of a whole	Understand fractions as part of a whole
	Fractions of measure	Understand fractions as a measure
	Fair shares	Understand fractions as the result of dividing up an amount
	Equivalence	Understand and recognise equivalent fractions
Week 6: Fractions 2	Comparing fractions	Comparing fractions through reasoning
	Common denominators	Comparing fractions accurately with common denominators
	Decimal fractions	Representing and comparing decimal fractions
	Mixed comparisons	Mixed fraction comparison methods
Week 7: Fractions 3	Modelling multiplication I	'Lots of' models
	Modelling multiplication II	Modelling connected calculations
	Multiplying fractions I	Fraction multiplication with area models
	Multiplying fractions II	Modelling decimal fraction multiplication
Week 8: Fractions 4	Dividing fractions by integers	Use pictorial models to divide fractions by integers
	Modelling division by fractions I	Modelling division as the result of a fraction multiplication
	Modelling division by fractions II	Modelling quotative division by fractions
	Fraction division in context	Fraction division in context including with units of measure
Week 9: Fractions 5	Adding and subtracting fractions	Adding and subtracting with common denominators
	Different denominators	Reasoning and estimating adding and subtracting with different denominators
	Using common denominators	Adding and subtracting with different denominators by using (lowest) common denominators
	Distributivity	Calculations involving the distributive property
Week 10: Percentage	Percentage number line	Representing fractions, decimal fractions and percentages on a number line
	Tenths, hundredths and thousandths	Writing percentages using composite base-10 place value
	Converting fractions and percentages	Using multiplicative relationships to convert fractions and percentages
	Percentages of quantities	Using bar models to find percentages of quantities

Week 1 Session 1: Translation

Task 1

Translations are movements in a direction.

Column vectors can be used to describe translations.

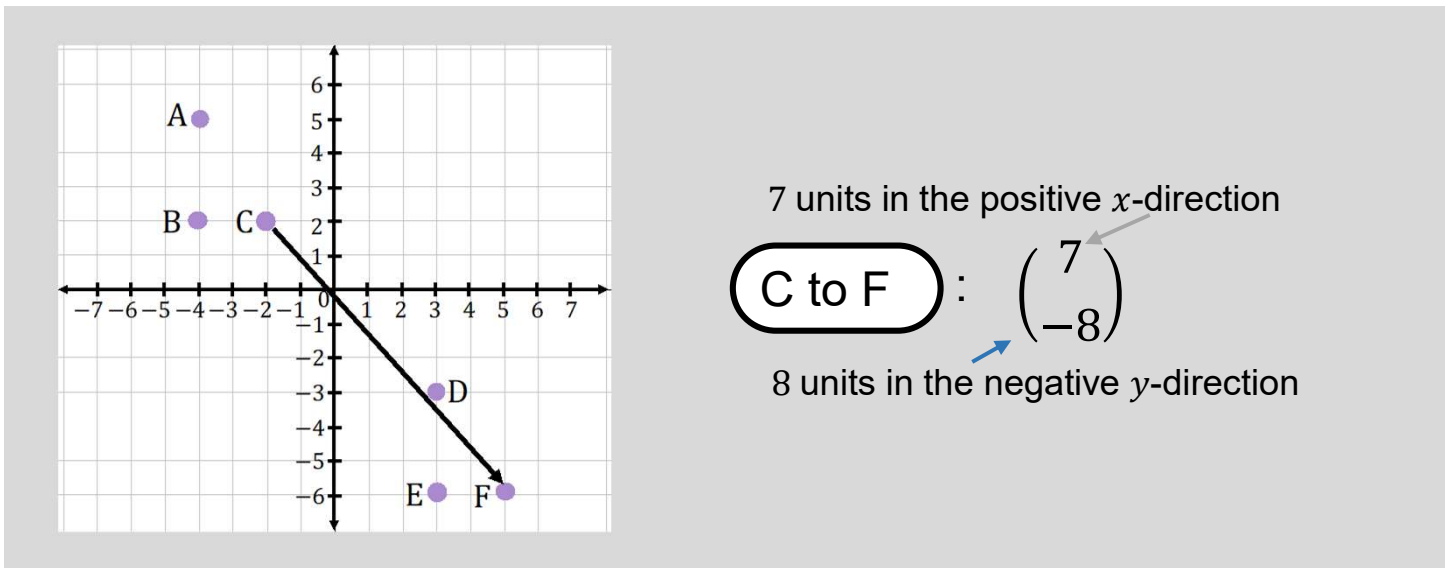

Write a vector that can describe the translations :

F to C

D to B

B to C

A to B

Task 2

Describe the translations from the central rectangle to the surrounding rectangles in each case.

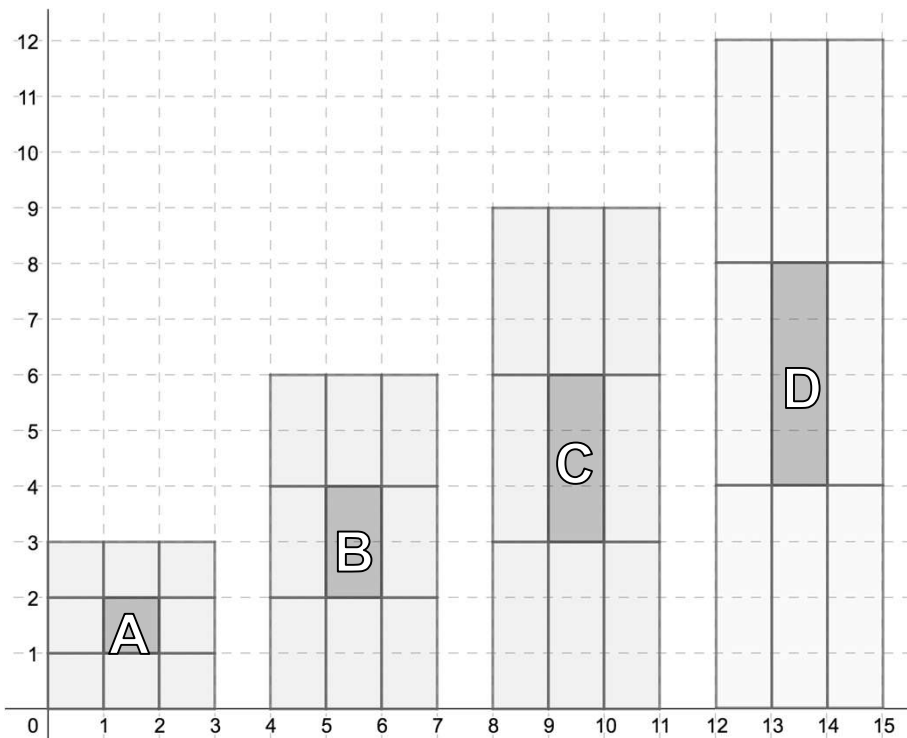

How could you continue this pattern?

Week 1 Session 2: Rotation

Task 1

We can rotate shapes about a **point of rotation**.

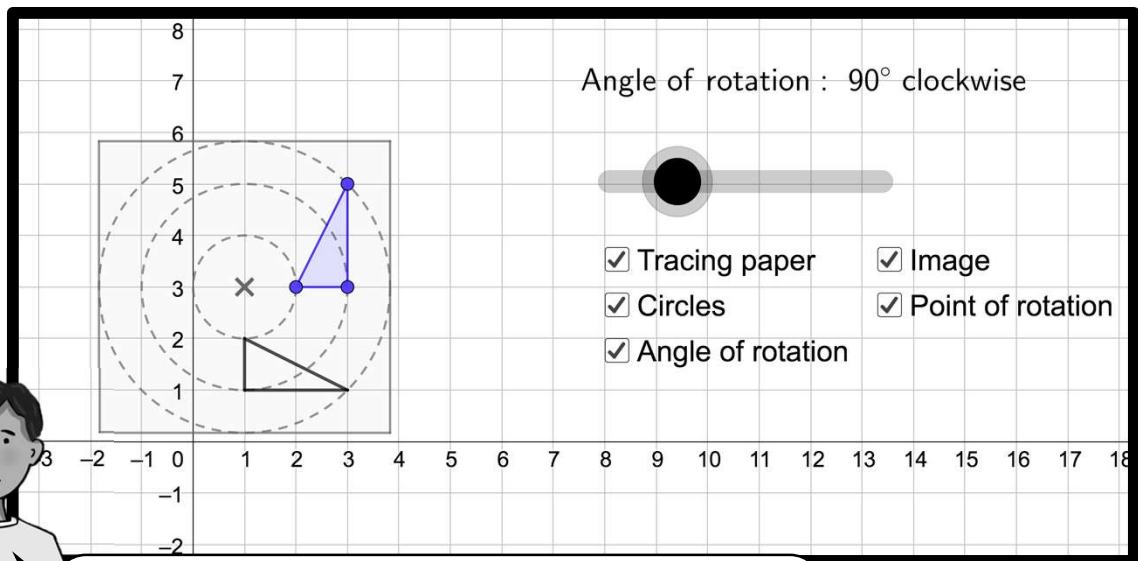

Access the Geogebra file on this link:
<https://www.geogebra.org/classic/vneqtrtf>

Task 2

Copy this image, rotate the hexagon 90° clockwise about the black crosses and 90° anticlockwise about the black dots.

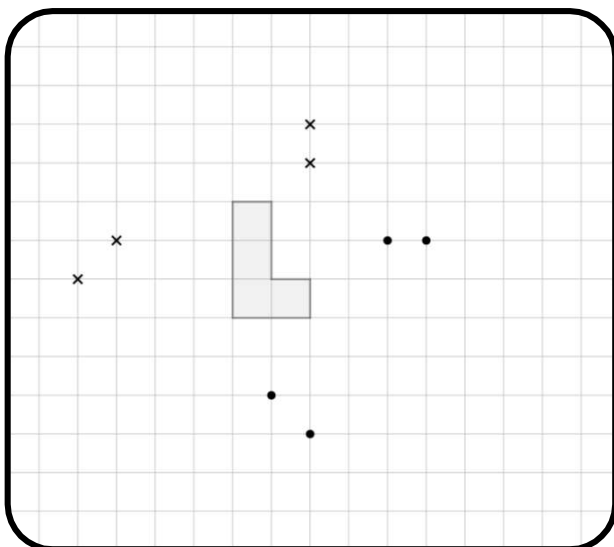

How would moving the points of rotation will affect the image?

Week 1 Session 3: Reflection

Task 1

We can reflect shapes in a line of reflection.

Points and their reflections will be equidistance from this line.

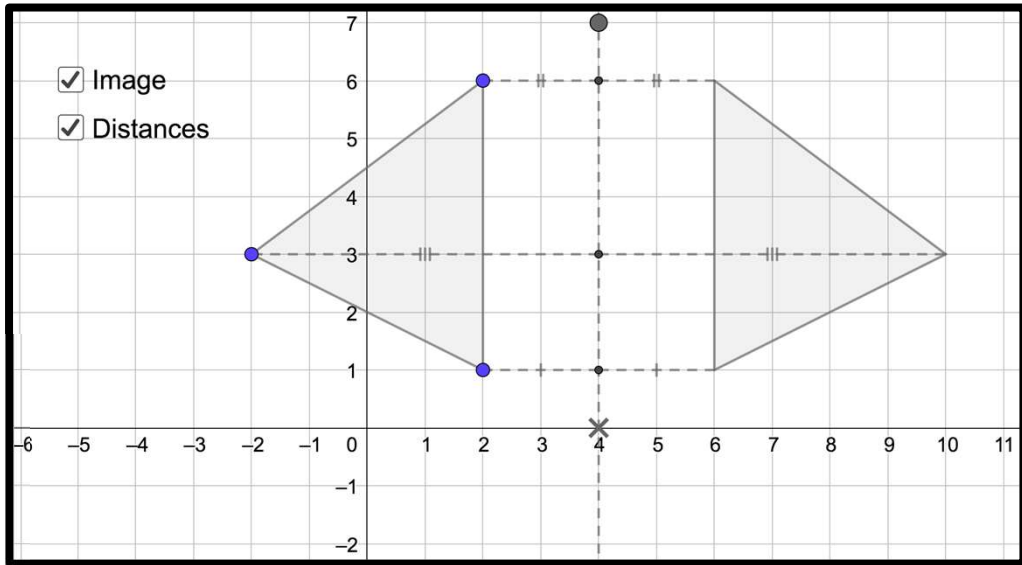

Access the Geogebra file on this link:
https://www.geogebra.org/classic/c5fmv_hfw

Task 2

T and U are reflections of S. What are the lines of reflection?

Explore the effect on the **reflected images** if **S** is translated by the vectors:

$\begin{pmatrix} 1 \\ 0 \end{pmatrix}$ $\begin{pmatrix} 0 \\ 1 \end{pmatrix}$ $\begin{pmatrix} 1 \\ -1 \end{pmatrix}$

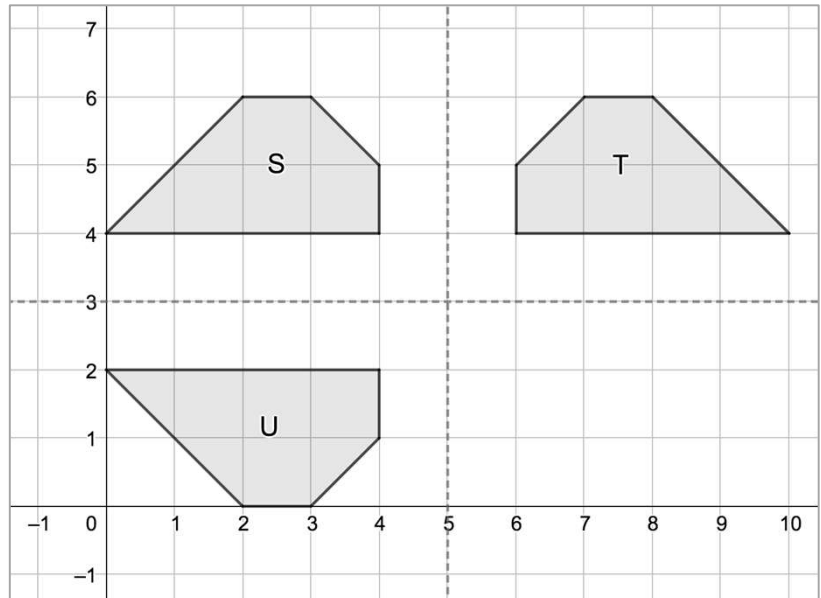

Week 1 Session 4: Isometries

Task 1

Copy and add in more examples and non examples

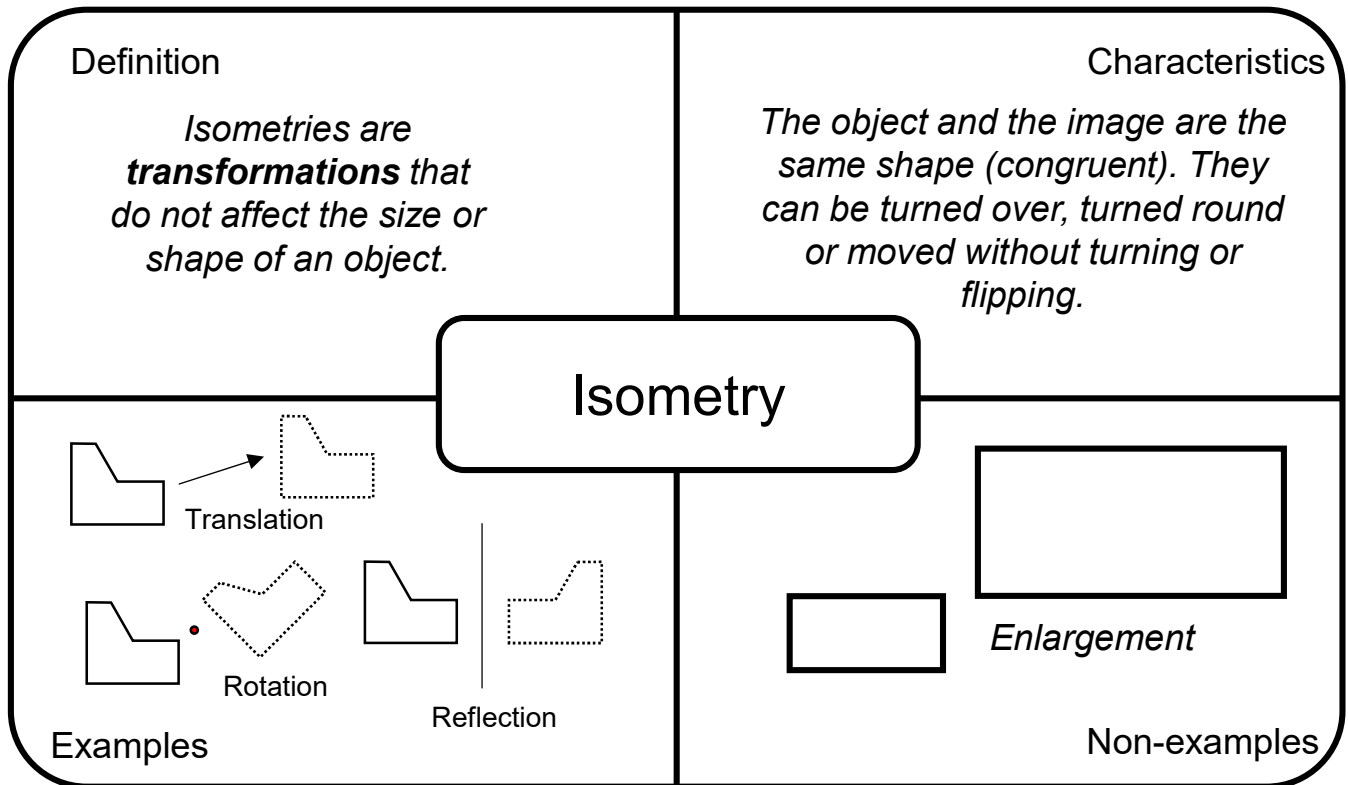

Task 2

There are different ways to transform one of the squares onto the other. Complete the descriptions:

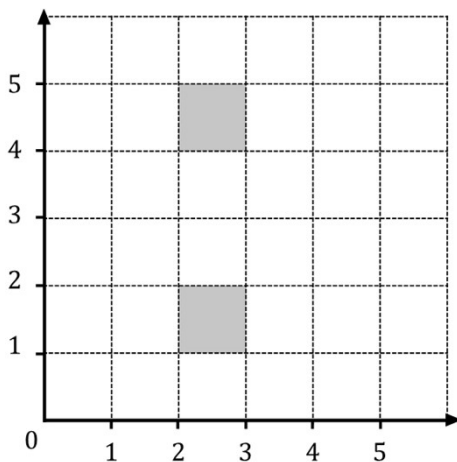

I reflected ...

I rotated ...

I translated ...

Week 2 Session 1: Combining reflections

Task 1

We can sometimes describe the effect of **combining** transformations using a single transformation.

Reflecting S in M_1 then in M_2 has the same effect as a translation

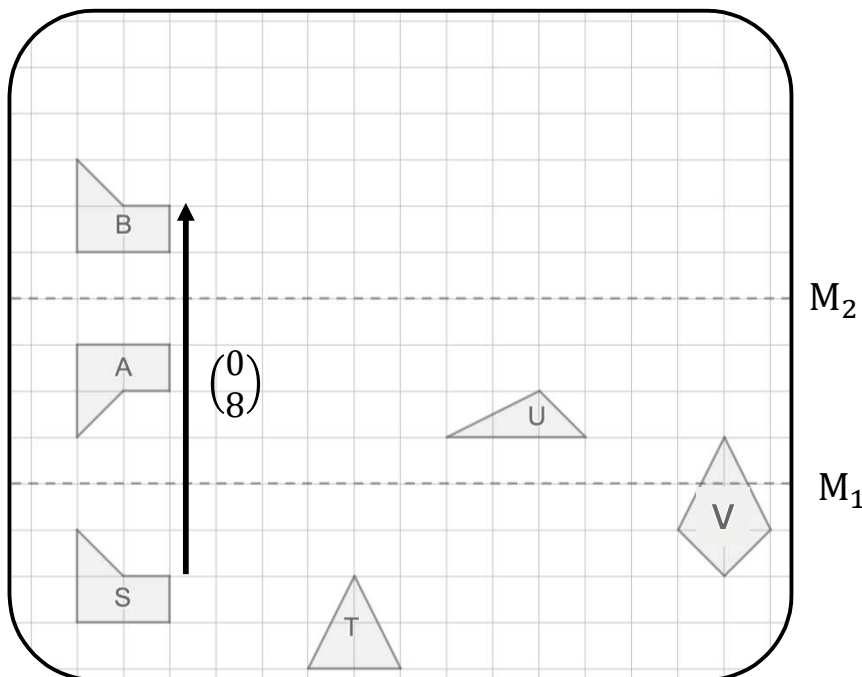

Explore the effect of this combination of reflections for: T, U and V.

Task 2

Reflect S in M_1 then in M_2 . Describe the single transformation from S to the final image.

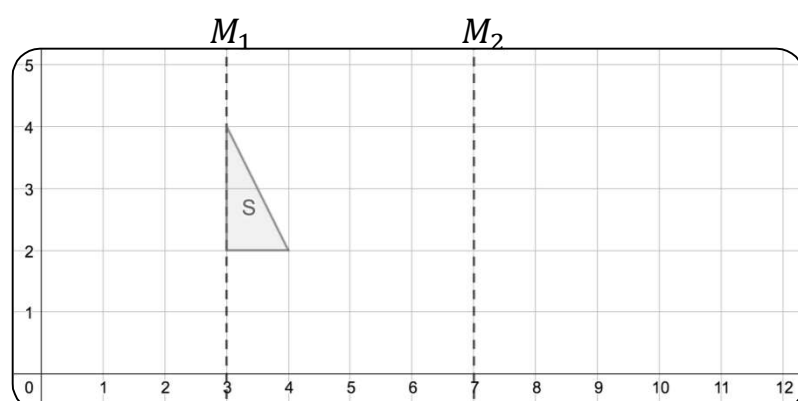
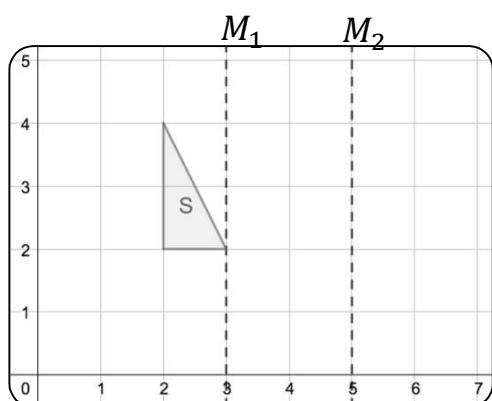
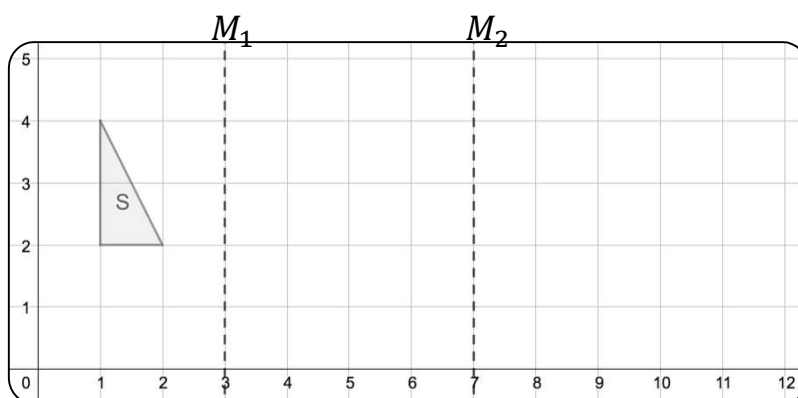
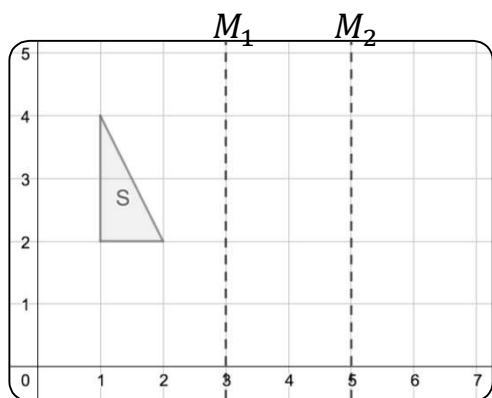

Week 2 Session 2: Combining translations and reflections

Task 1

Describe the transformation, or combination of transformations, between each pair of triangles:

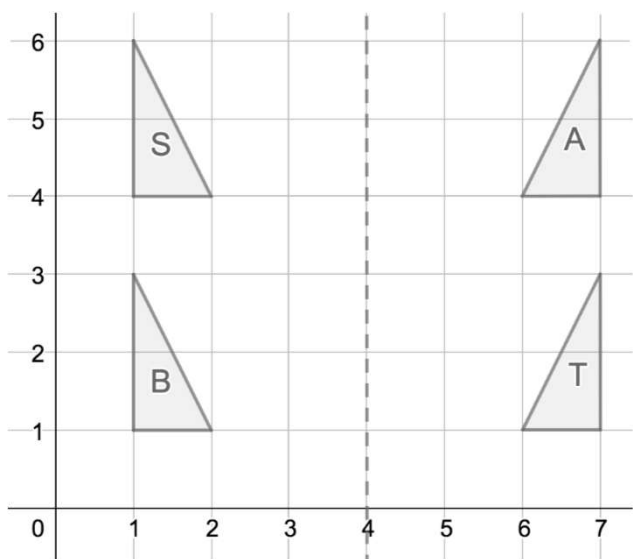

e.g. Triangle T is the reflection of triangle S in the line $x = 4$ followed by a translation by the vector $\begin{pmatrix} 0 \\ -3 \end{pmatrix}$

Task 2

Using the line of symmetry shown, compare the effect of...

- reflecting then translating
- translating then reflecting

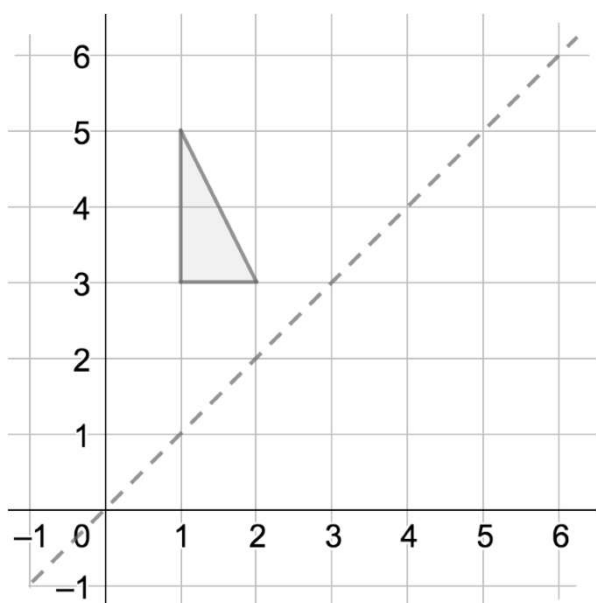

... for each of the vectors:

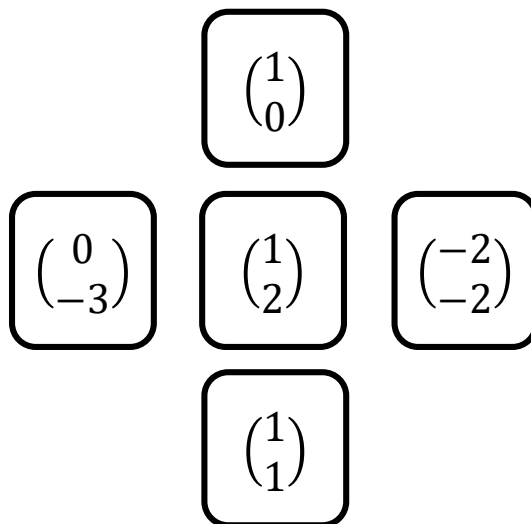

Week 2 Session 3: Enlargement

Task 1

Enlargements of shapes can be described using **scale factors**.

T is an enlargement of S by a scale factor 2

S is an enlargement of T by a scale factor $\frac{1}{2}$

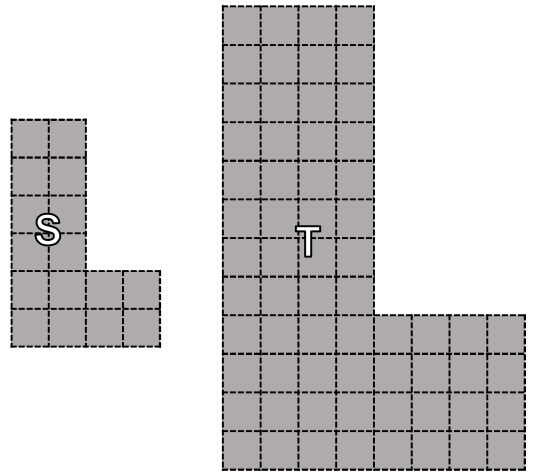

Draw S following an enlargement of scale factor:

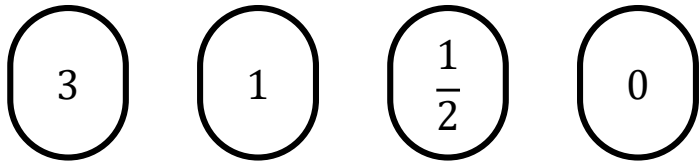

Task 2

Explain why B is not an enlargement of A.

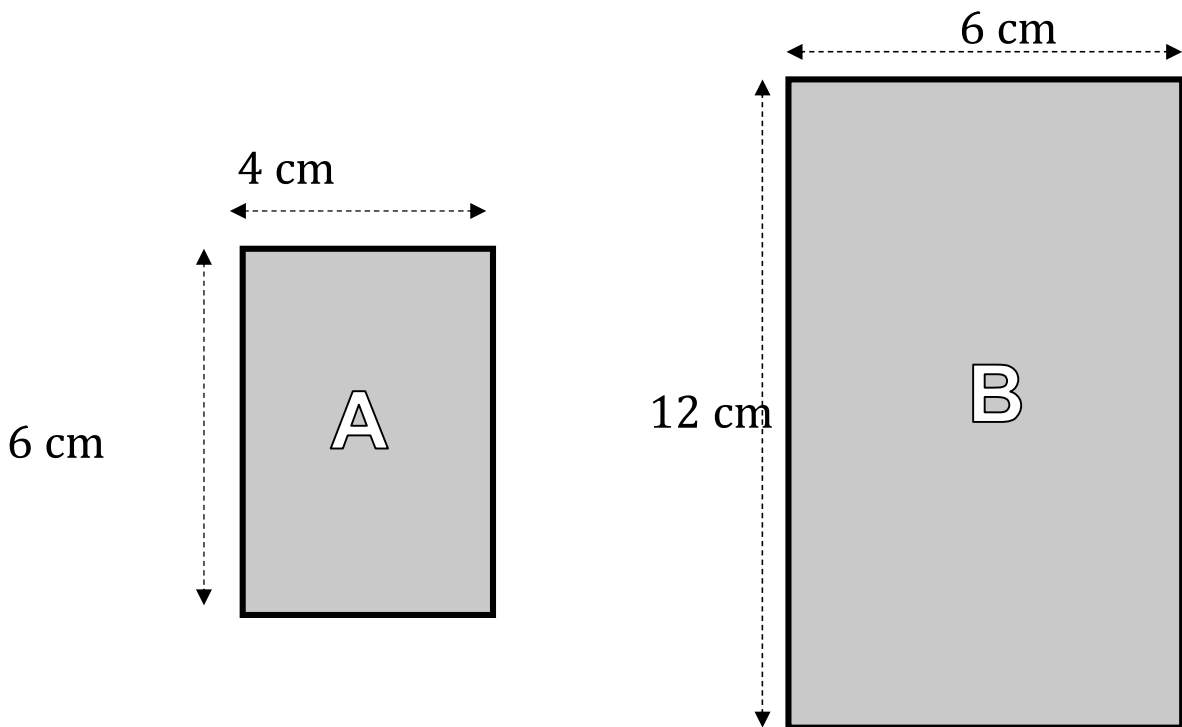

How could you change **one of the dimensions** of A or B so that it is?

Week 2 Session 4: Enlargement and area

Task 1

When a shape is enlarged the **area** is affected.

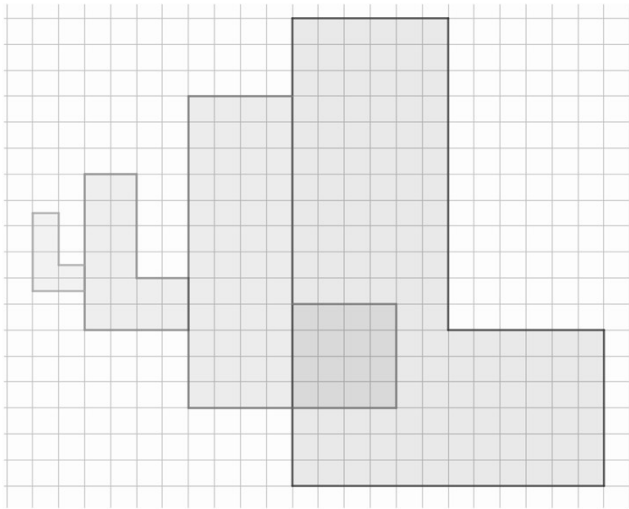

Find the scale factor of enlargement between the different shapes.

How has the area been affected in each case?

Task 2

Draw **sketches** of the following shapes after they're enlarged by a scale factor 7.

How do enlargements affect the areas?

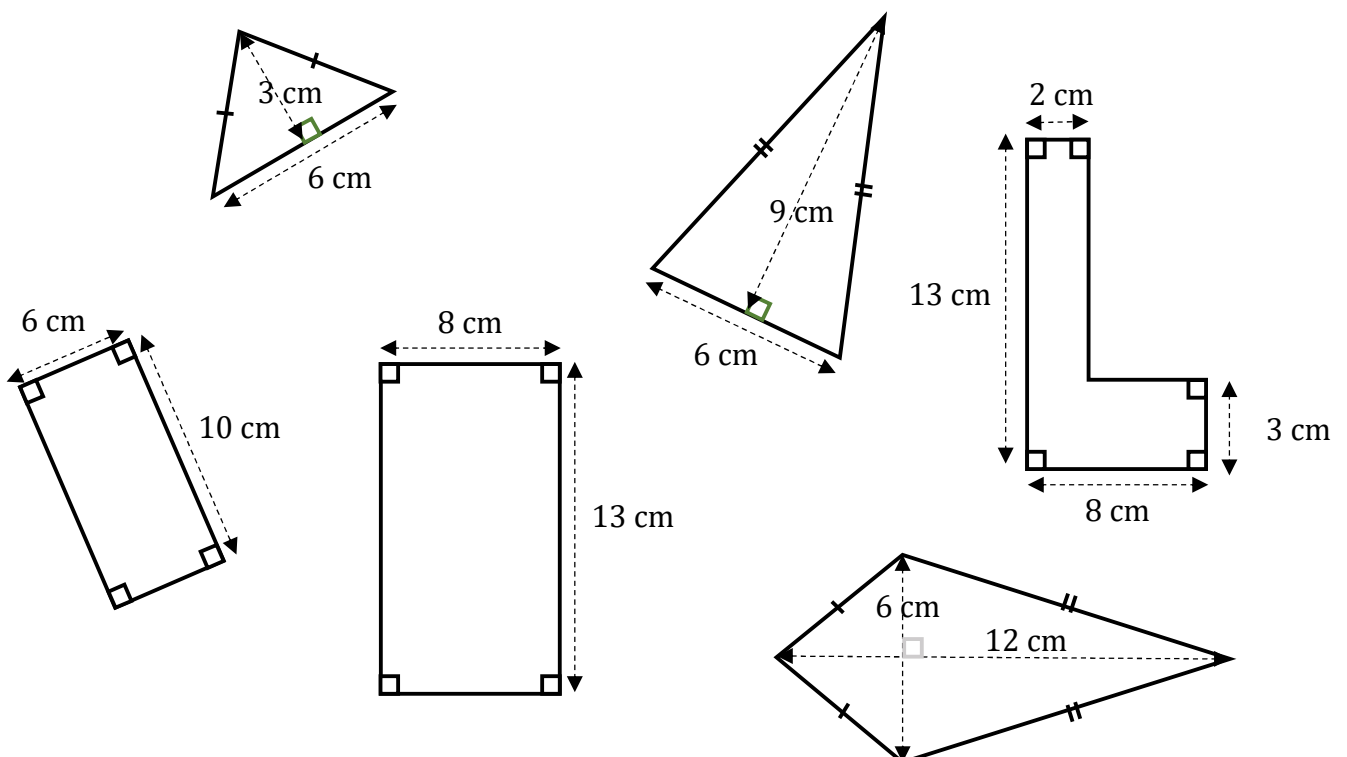

Week 3 Session 1: Indices

Task 1

We can use index notation to describe repeated products.

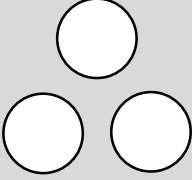
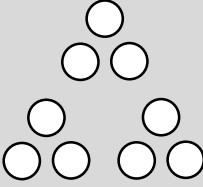
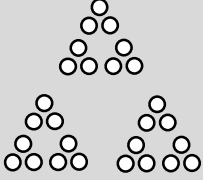
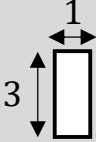
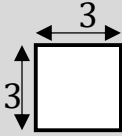
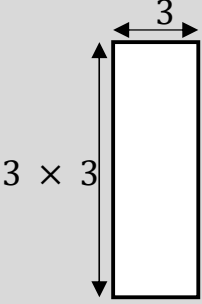
$3^1 = 3$	$3^2 = 3 \times 3$	$3^3 = 3 \times 3 \times 3$
		
		

Connect each representation to the calculation.

How could you represent 3^4 ?

Task 2

Is this student correct? Test out her conjecture by trying out other powers.

TIP: You should use at least 8 calculations.

$$3^2 = 3 \times 3 = 9$$

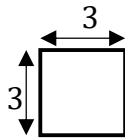

For even powers the result is always a square number

$$2^4 = 2 \times 2 \times 2 \times 2 = 16$$

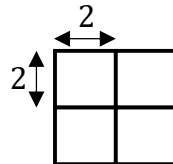

Test out some conjectures of your own.

For example, *odd numbers raised to any power are always odd* OR *the final digit of a power of 2 is always a 2, 4, 6 or 8.*

Week 3 Session 2: Prime factors

Task 1

If you multiply ONLY 1s and 2s, you can make the products 1,2,4,8,16,32 and 64. These have been shaded grey on the grid.

Write down (or circle on the grid) the other numbers that could you make if you are now able to multiply together combinations of 1s, 2s and 3s.

TIP: you do not have to use 1,2 and 3 in each calculation.



1	2	3	4	5	6	7	8	9	10
11	12	13	14	15	16	17	18	19	20
21	22	23	24	25	26	27	28	29	30
31	32	33	34	35	36	37	38	39	40
41	42	43	44	45	46	47	48	49	50
51	52	53	54	55	56	57	58	59	60
61	62	63	64	65	66	67	68	69	70
71	72	73	74	75	76	77	78	79	80
81	82	83	84	85	86	87	88	89	90
91	92	93	94	95	96	97	98	99	100



Task 2

These students are discussing what happens when you include 4s:



1	2	3	4	5	6	7	8	9	10
11	12	13	14	15	16	17	18	19	20
21	22	23	24	25	26	27	28	29	30
31	32	33	34	35	36	37	38	39	40
41	42	43	44	45	46	47	48	49	50
51	52	53	54	55	56	57	58	59	60
61	62	63	64	65	66	67	68	69	70
71	72	73	74	75	76	77	78	79	80
81	82	83	84	85	86	87	88	89	90
91	92	93	94	95	96	97	98	99	100



Do you agree? Explain your answer.

Explain what will change when 5s are included.

Week 3 Session 3: Prime factorisation

Task 1

Every compound integer can be written as a **product** of prime numbers.

$$30 = 2 \times 3 \times 5$$

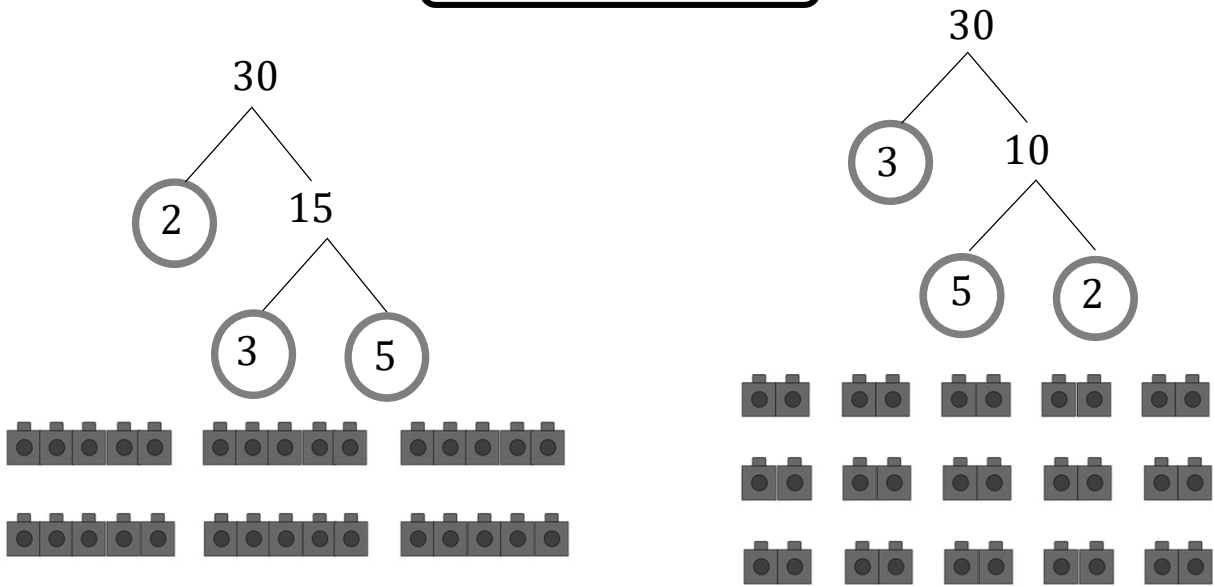

What's the same, what is different about these two representations?

Task 2

Write each of these as a product of prime numbers:

50

150

50×10

50^2

24

72

24×10

24^2

Week 3 Session 4: Using the prime factorisation

Task 1

Here are all the factors of 60.

Write each one as a product of prime factors.

60	30	20	15	12	10
1	2	3	4	5	6

Compare the prime factorisation of 60 with the prime factorisation of its factors.

What do you notice?

Task 2

Help Phil to find **all** the factor pairs for this number:

$$2 \times 5^2 \times 7$$

$$2 \times 5 \times 7$$

$$5$$

$$5 \times 7$$

$$5 \times 2$$

⋮

⋮



Week 4 Session 1: Highest common factor

Task 1

Two students are looking at the **common factors** of 48 and 32:

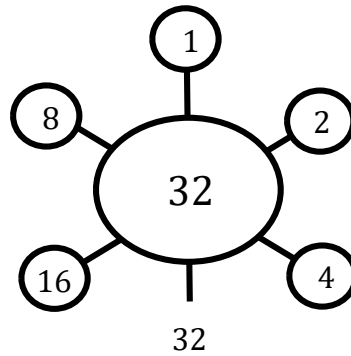
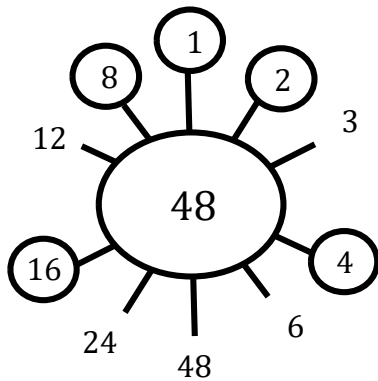

They are the factors of 16!

16 is the highest common factor.

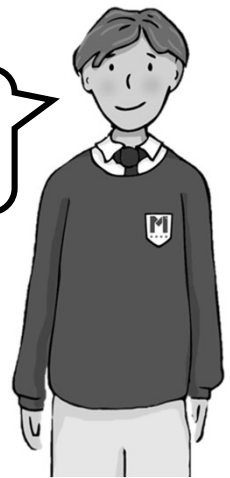

What does Ali mean when he says the '*highest common factor*'?

Task 2

This rectangle has been divided into identical squares.

What is the side length of the squares?

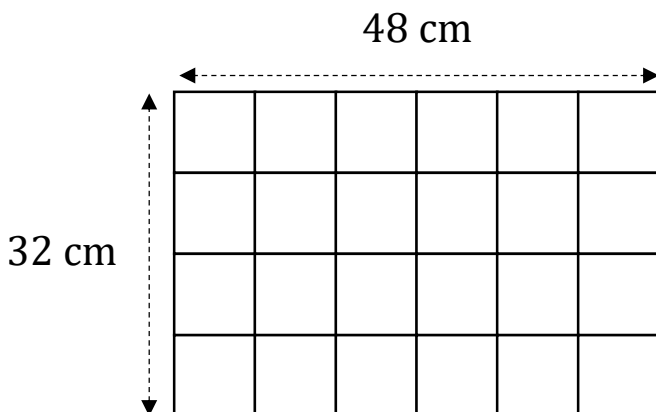

I think these are the largest possible squares.

Do you agree with the student's statement?
What other sized squares can you divide it into?

Explore the different sizes of identical squares that can fit in a 12 cm × 24 cm rectangle. What about an 18 cm × 24 cm rectangle?

Week 4 Session 2: More highest common factor

Task 1

Venn Diagrams can be used to identify common factors.

$$24 = \underline{2 \times 2} \times 2 \times 3$$

$$36 = \underline{2 \times 2} \times 3 \times 3$$

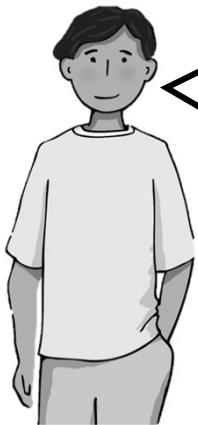

4 is a common factor!

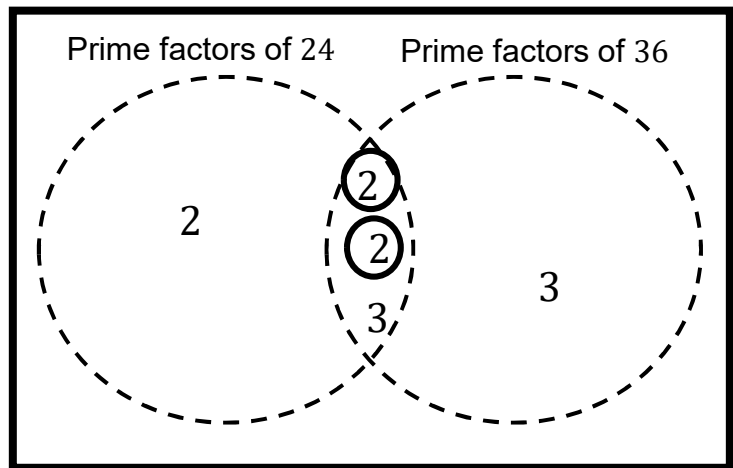

What other common factors can you see?

Task 2

Copy the diagrams below. Explain how each strategy can help find the HCF.

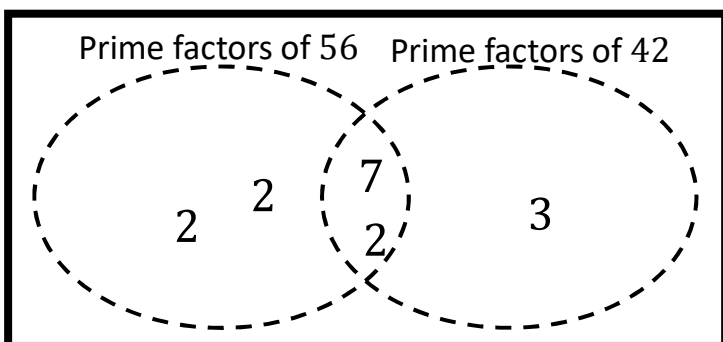
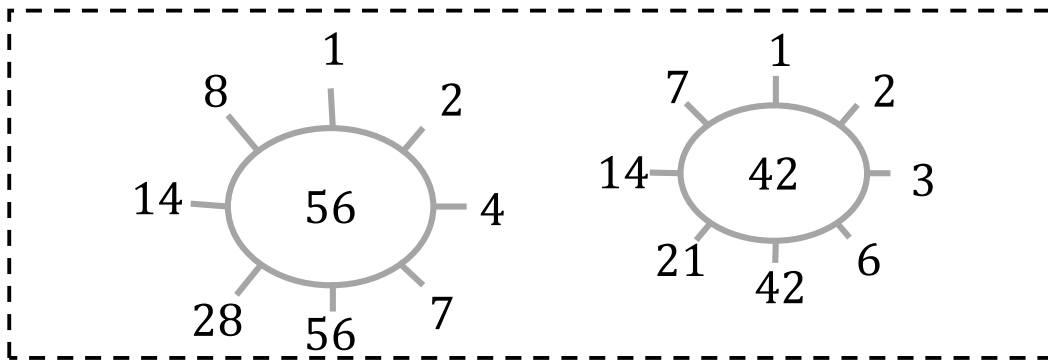

$$56 = 2 \times 2 \times 2 \times 7$$

$$42 = 2 \times 3 \times 7$$

Week 4 Session 3: Lowest common multiple

Task 1

Copy the diagram below. Continue the pattern to help Rosie find the **common multiples** of 45 and 60 up to 180.

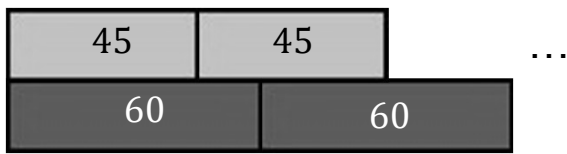

What is the lowest common multiple of 45 and 60 ?

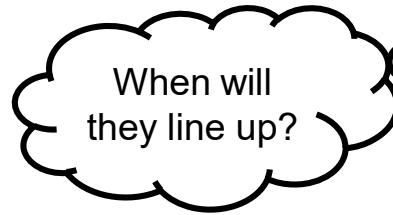

Complete more examples for different pairs of numbers.

Task 2

Select two of the numbers from the list below.
By drawing diagrams and/or listing numbers, find their lowest common multiple:

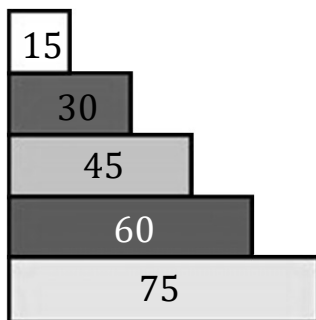

Repeat this for another **three** pairs of numbers.

What do you notice?

Week 4 Session 4: More lowest common multiple

Task 1



By continuing the pattern above, find the **first five** common multiples of 12 and 9.

Write each as a product of their prime factors.

What similarities are there between each of the product of prime factors?

Task 2

Explain how each strategy can help find the LCM.

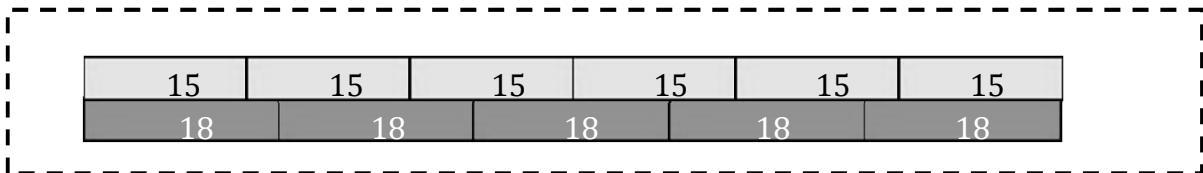

18, 36, 54, 72, 90, 108 ...

15, 30, 45, 60, 75, 90 ...

Prime factors of 18 Prime factors of 15

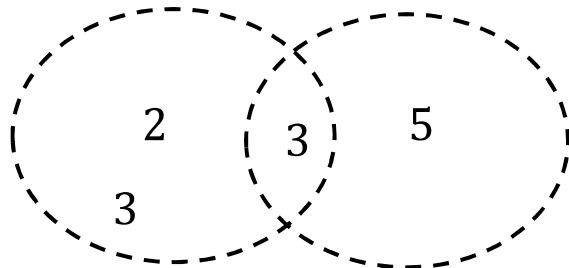

$$90 = \underbrace{2 \times 3 \times 3}_{18} \times \overbrace{3 \times 5}^{15}$$

Week 5 Session 1: Part of a whole

Task 1

We can use fractions to describe **equal parts** of a whole.

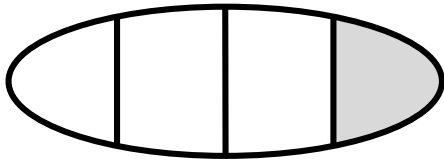

This is not $\frac{1}{4}$

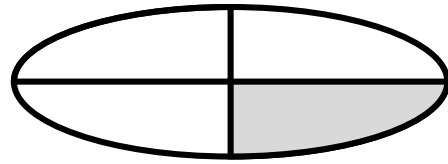

This is $\frac{1}{4}$

Complete the statements below:



This is 1

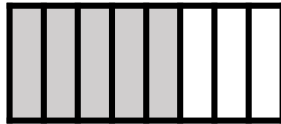

This is $\frac{?}{8}$

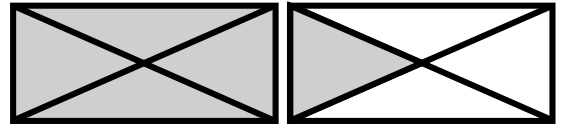

This is $\frac{5}{?} = 1\frac{1}{?}$

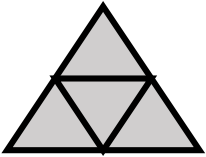

This is 1

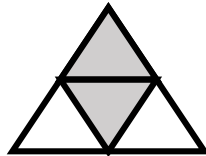

This is...

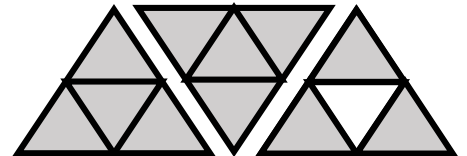

This is...

Task 2

Complete the statements for each set of shapes

Example

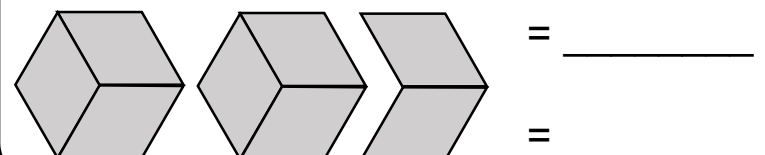
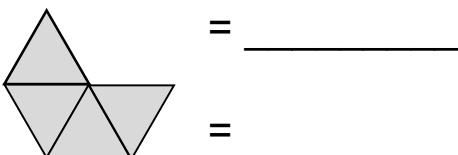
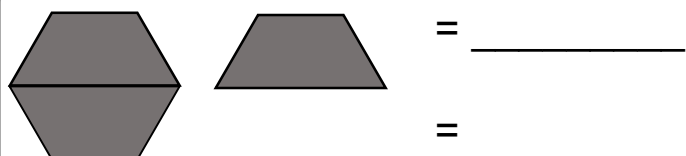
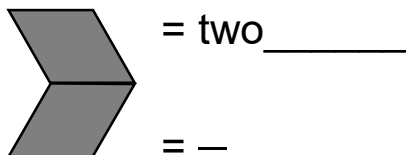
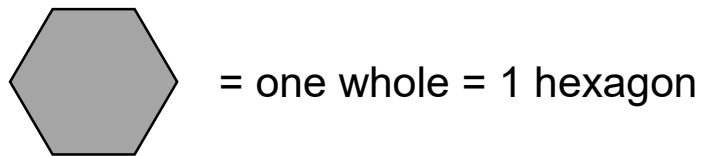
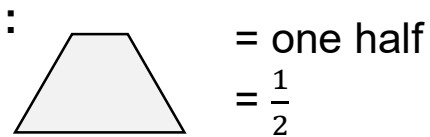

Week 5 Session 2: Fractions of measure

Task 1

This is a fully-shaded 1 metre bar: 

What fraction of a 1 metre bar is shaded in each diagram?

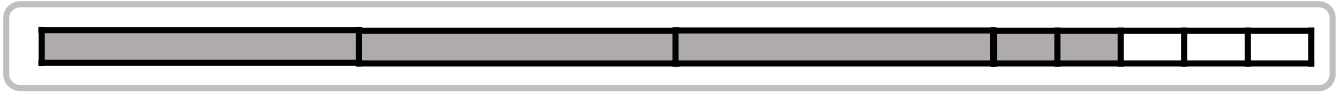

What fraction of the 1/ of orange juice is shown in each diagram?



1/

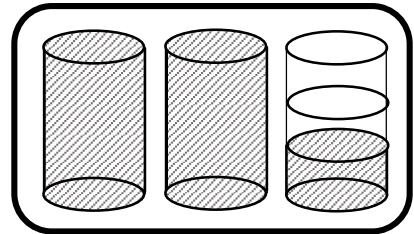
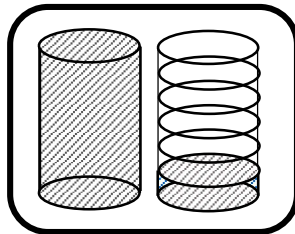
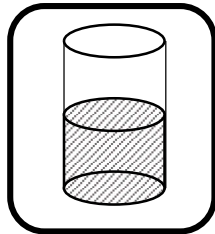

Task 2

This rectangle represents a farm of area 6 acres.



The diagrams below show the farm divided up in two different ways.

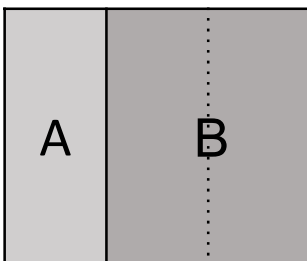

Use the diagrams to complete the statements:

Section A is _____ of the farm or **2** acres

Section B is _____ of the farm or _____ acres

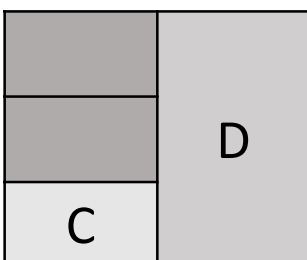

Section C is _____ of the farm or _____ acres

Section D is $\frac{1}{2}$ of the farm or _____ acres

Week 5 Session 3: Fair shares

Task 1

Two bars of chocolate are shared **equally** by three children.

They get $\frac{2}{3}$ of a bar each.

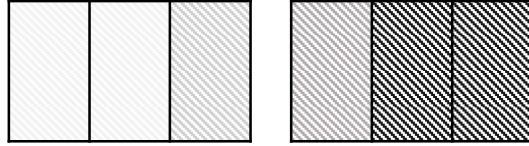

Use some scrap paper to see if you can share two chocolate bars between three children using different cuts.

What would happen to the amount of chocolate each child gets if...

- a) The number of children they are sharing between goes up
- b) The number of chocolate bars they have goes up

Task 2

Look at how chocolate is shared in the two groups below.

Group A

Five bars of chocolate are shared equally by two children.

Group B

Seven bars of chocolate are shared equally by three children.

Who gets more chocolate? Use a diagram to help explain your answer.

Try different numbers of chocolate bars and different numbers of children.

Can you create two **different** groups where each child gets the **same** amount of chocolate?

Week 5 Session 4: Equivalence

Task 1

There are many ways to write fractions that represent the same value

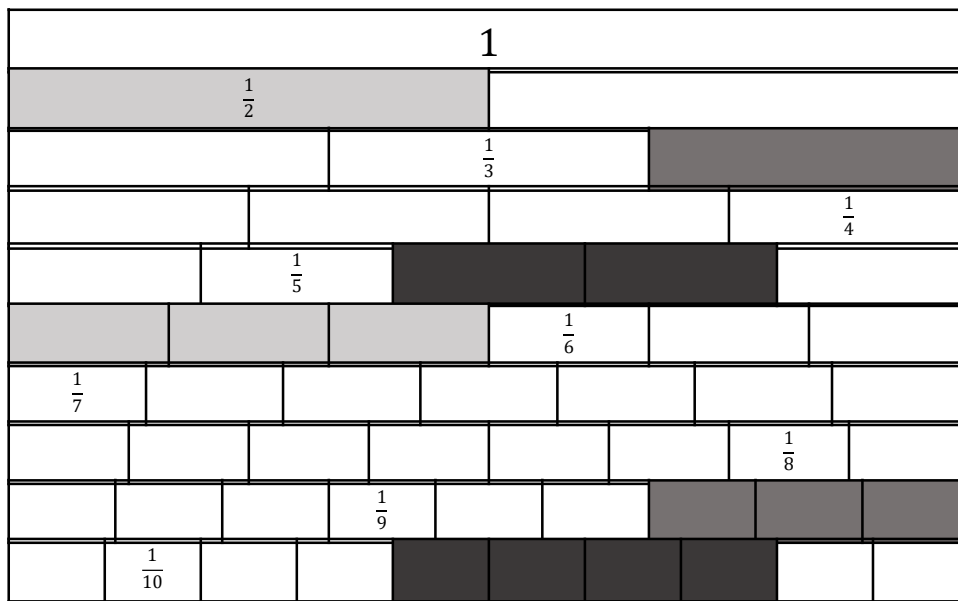

~~$\frac{1}{2} = \frac{3}{6}$~~

~~$\frac{1}{3} = \frac{\square}{9}$~~

~~$\frac{\square}{\square} = \frac{\square}{\square}$~~

Find other equivalent fractions from the diagram

Task 2

Fill in the blanks below

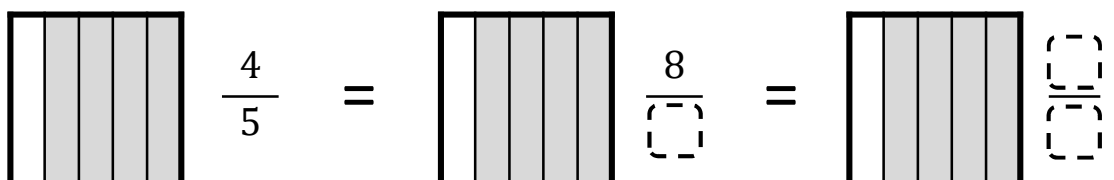
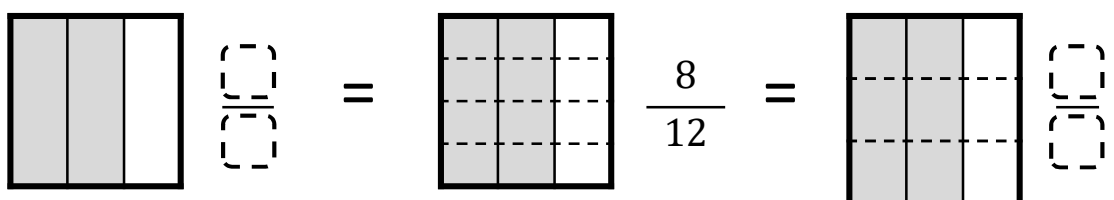
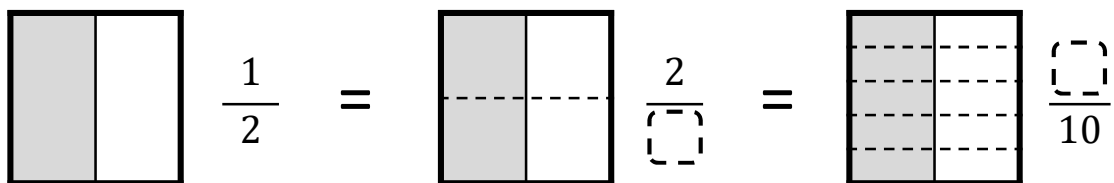
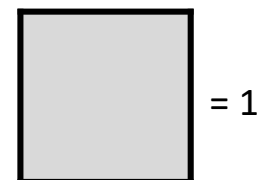

Week 6 Session 1: Comparing fractions

Task 1

Which is greater?

$$\frac{5}{6} \text{ or } \frac{6}{7}$$

How many ways can you explain how to decide which is greater?

Find ways to explain or using diagrams to show which fraction is greater:

$\frac{4}{5}$ or $\frac{7}{8}$	$\frac{3}{7}$ or $\frac{5}{9}$
$\frac{11}{10}$ or $\frac{24}{25}$	$\frac{3}{5}$ or $\frac{4}{7}$

Bar models and number lines might help you explain.

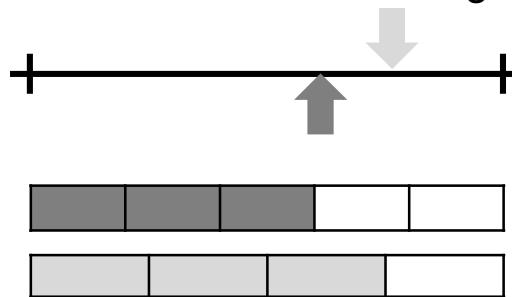

Task 2

Start in the top left grey square. You can only move $\leftarrow \rightarrow \uparrow \downarrow$ to squares that have a **lower** value (no diagonal moves).

How many paths can you find to reach the bottom right grey square?

How many squares are impossible to visit?

Explain how you knew which fractions had a lower value.

Start				
$1\frac{4}{5}$	$\frac{8}{5}$	$1\frac{1}{2}$	$\frac{4}{3}$	$\frac{5}{4}$
$\frac{3}{2}$	$\frac{17}{8}$	$1\frac{1}{12}$	$\frac{5}{3}$	1
$1\frac{1}{4}$	$\frac{9}{8}$	$\frac{5}{6}$	1	$\frac{2}{3}$
$\frac{7}{8}$	$\frac{8}{7}$	$\frac{1}{2}$	$\frac{1}{5}$	$\frac{1}{4}$
$\frac{3}{4}$	$\frac{2}{3}$	$\frac{1}{3}$	$\frac{1}{6}$	$\frac{1}{8}$

Finish

Week 6 Session 2: Common denominators

Task 1

Look at the different models these students have used to compare $\frac{2}{3}$ and $\frac{3}{4}$.

I can see which fraction is greater.

I can see *how much* greater....

Compare their methods. What's the same? What's different?

Draw your own model to compare $\frac{5}{6}$ and $\frac{3}{4}$. What do you notice?

Task 2

We can use common denominators to compare *how much* greater one fraction is than another.

$$\frac{1}{4} = \frac{5}{20}$$

$$\frac{2}{5} = \frac{8}{20}$$

So $\frac{2}{5}$ is $\frac{3}{20}$ **greater** than $\frac{1}{4}$

Work out the distances between the fractions on the number line. Some distances have been marked for you with arrows.

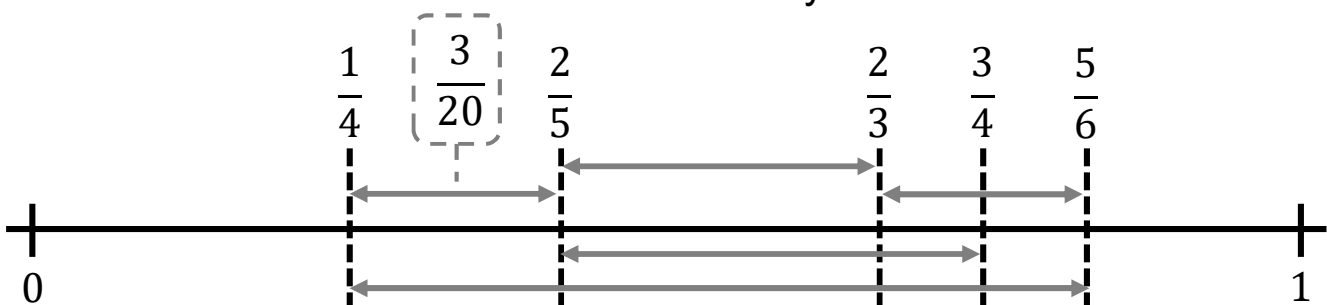

Week 6 Session 3: Decimal fractions

Task 1

When the denominator of a fraction is a power of 10 (e.g. 10, 100, 1000) we can write the fraction differently.

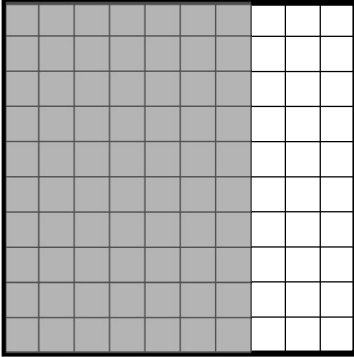

$$\frac{70}{100} = \frac{7}{10} = 0.7$$

How many ways could you write the fractions shaded below?

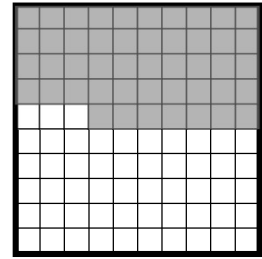
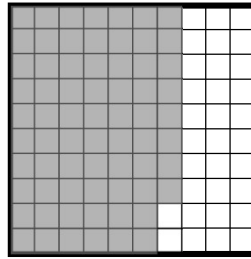
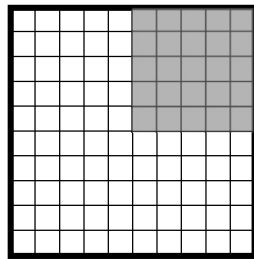
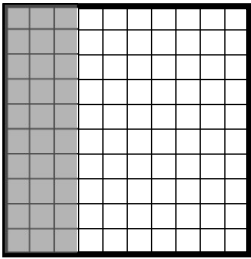

Task 2

Put the cards below in ascending order.

Number cards arranged in a grid:

$\frac{1}{10}$	0.05	$\frac{3}{10}$	$\frac{15}{100}$	$\frac{1}{5}$
	0.5	$\frac{4}{10}$	0.75	
		$\frac{11}{20}$		

The sum of the number cards above is 3.

They can be organized into **3 groups** each with a sum of 1.

Find these groups.

Week 6 Session 4: Mixed comparisons

Task 1

Choose pairs of fractions from each set. Compare them and decide which is greater. Which different comparison strategies did you use? Some example strategies have been written below.

$\frac{4}{5}$	$\frac{6}{5}$	$\frac{5}{4}$
$\frac{6}{4}$	$\frac{5}{6}$	$\frac{4}{6}$

$\frac{7}{5}$	$\frac{7}{4}$	$\frac{5}{4}$
$\frac{5}{7}$	$\frac{4}{7}$	$\frac{4}{5}$

I knew which fraction was greater / smaller because I ...

... compared their numerators / denominators...

... wrote them as decimals...

... compared both fractions to $1, \frac{1}{2}$, etc ...

... wrote equivalent fractions with common denominators ...

Task 2

Draw a number line from -2 to 2 and **estimate** where the numbers in the box lie on it.

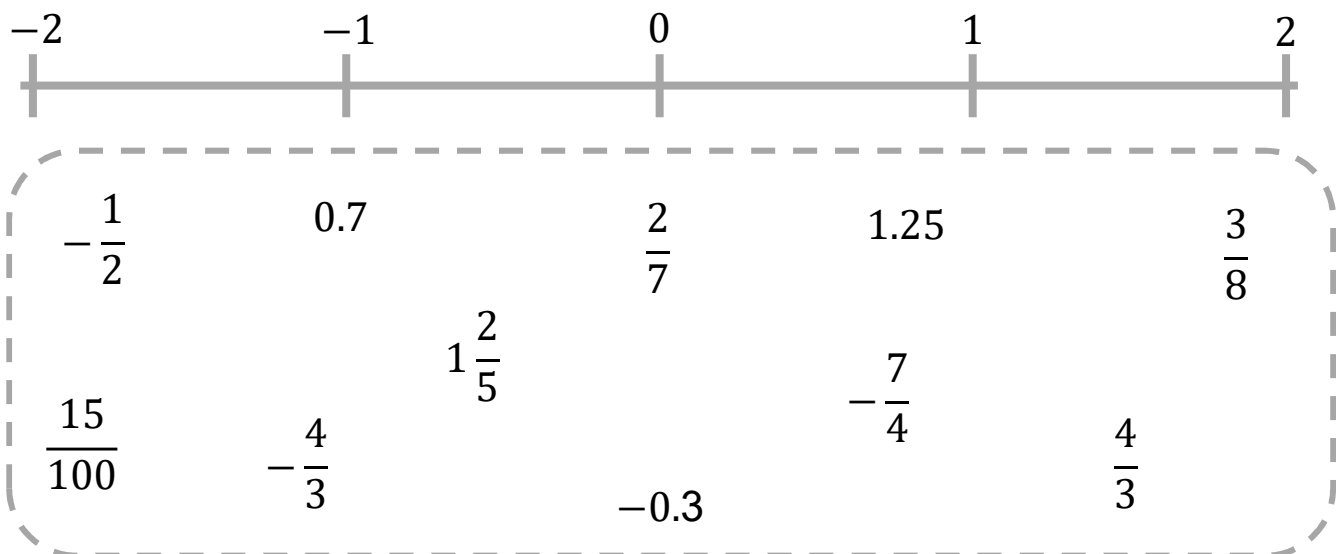

Write a fraction that lies in **each gap** between the numbers on your number line.

Week 7 Session 1: Modelling multiplication I

Task 1

Two students are working out the product of 12 and $\frac{1}{3}$

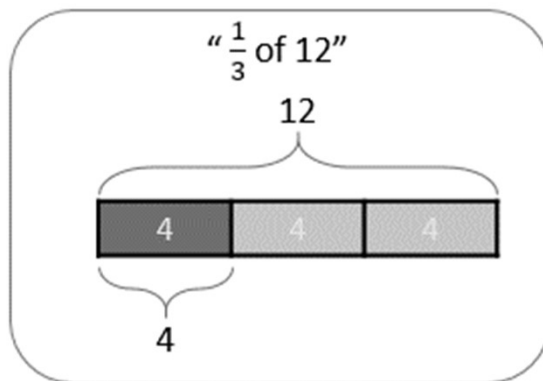
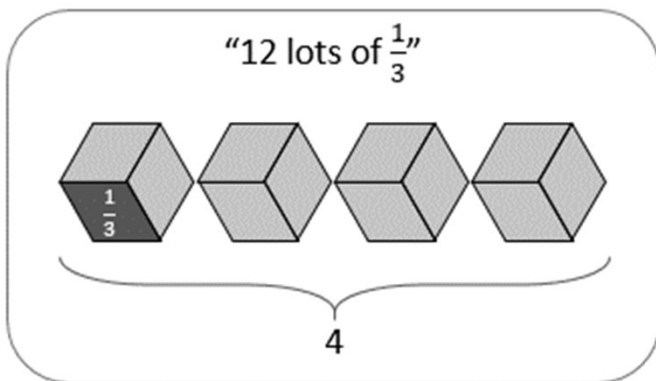

Draw two diagrams that represent:

$$10 \times \frac{1}{5}$$

$$\frac{1}{2} \times 5$$

$$9 \times \frac{1}{3}$$

$$\frac{1}{4} \times 12$$

Use these diagrams to find the answers

Task 2

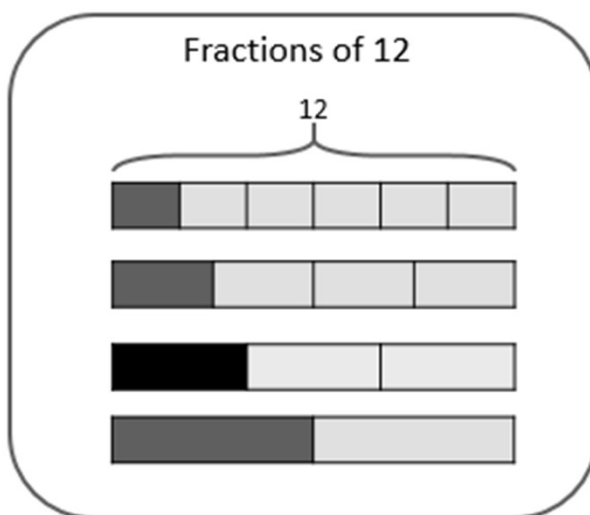
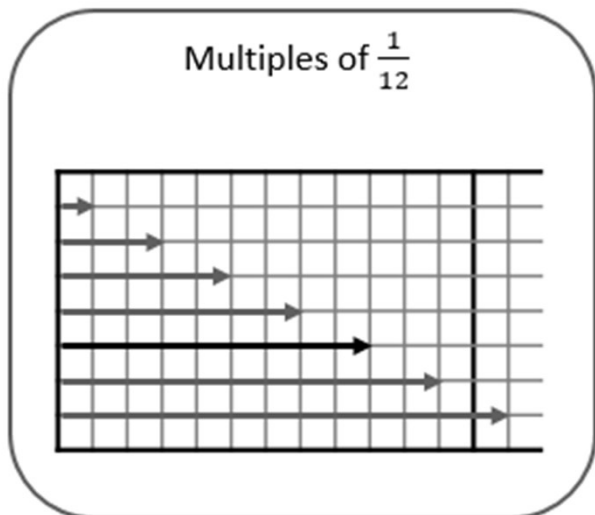

Sentences have been written to describe the black examples:

$$9 \text{ lots of } \frac{1}{12} = \frac{9}{12} = \frac{3}{4}$$

$$\frac{1}{3} \text{ of } 12 = 4 = 12 \div 3$$

Write similar sentences to describe the other parts of the diagram

Week 7 Session 2: Modelling multiplication II

Task 1

This diagram shows the first three multiples of $\frac{2}{3}$.

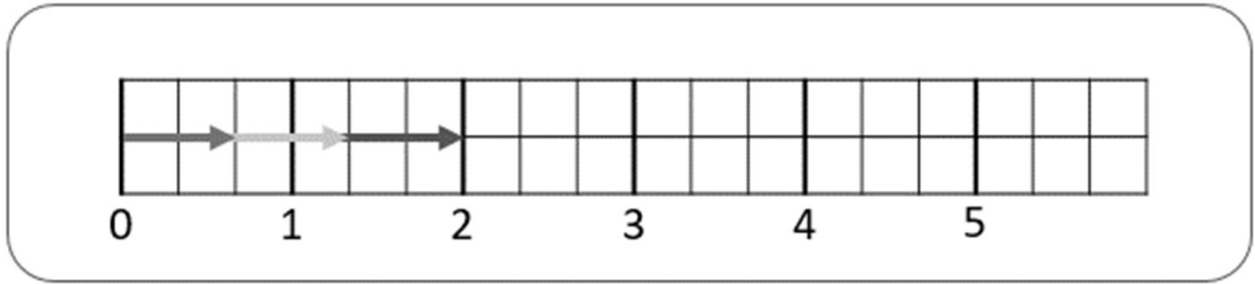

Hannah looks at 2 lots of $\frac{2}{3}$ and writes some calculations...

$$2 \times \frac{2}{3} = \frac{4}{3} \qquad \frac{2}{3} \times 2 = \frac{4}{3} \qquad \frac{4}{3} \div 2 = \frac{2}{3} \qquad \frac{4}{3} \div \frac{2}{3} = 2$$

Extend this diagram to work out more multiples of $\frac{2}{3}$.

Write similar statements for each multiple of $\frac{2}{3}$.

Task 2

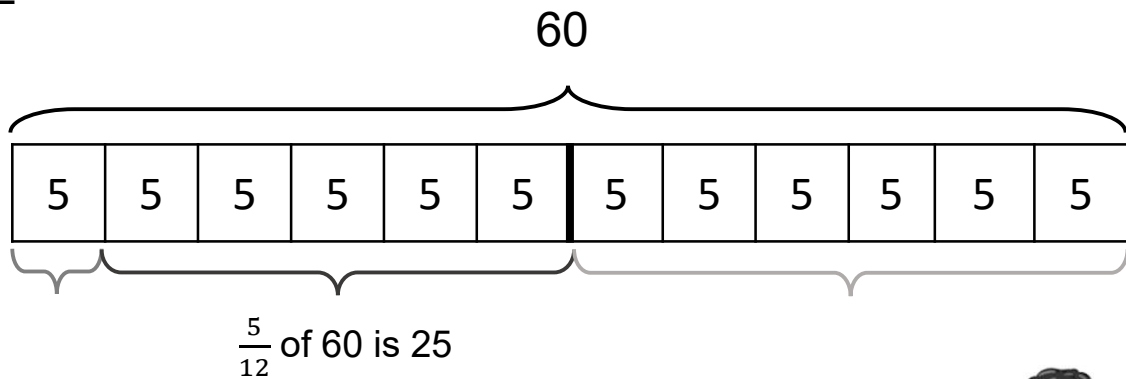

Therefore:

$$\frac{5}{12} \times 60 = 25$$

$$60 \times \frac{5}{12} = 25$$

$$25 \div 60 = \frac{5}{12}$$

$$25 \div \frac{5}{12} = 60$$



What other calculations can you find from the diagram?

Draw a diagram that can be used to find $\frac{2}{5}$ and $\frac{3}{5}$ of 60.

Week 7 Session 3: Multiplying fractions I

Task 1

Two students are looking at this model to multiply $\frac{1}{4}$ and $\frac{1}{5}$



The bottom row is $\frac{1}{4}$, so the darkest block is $\frac{1}{5}$ of $\frac{1}{4}$.



The left column is $\frac{1}{5}$, so the darkest block is $\frac{1}{4}$ of $\frac{1}{5}$.

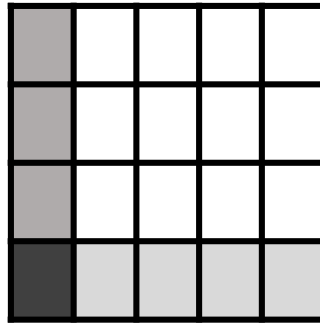

$$\frac{1}{4} \times \frac{1}{5} = \frac{1}{20}$$

Fill in the blanks to complete these calculations:

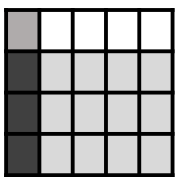

$$\frac{3}{4} \times \frac{1}{5} = \frac{\square}{20}$$

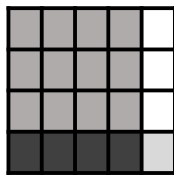

$$\frac{1}{4} \times \frac{\square}{\square} = \frac{\square}{20}$$

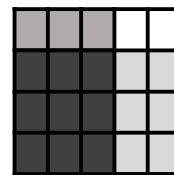

$$\frac{\square}{\square} \times \frac{\square}{\square} = \frac{9}{20}$$

Can you find two fractions that multiply together to make $\frac{12}{20}$?

Can you find two fractions that multiply together to make $\frac{12}{35}$?

Task 2

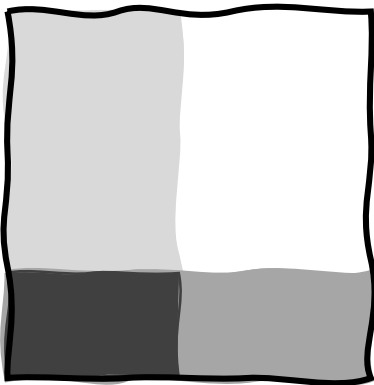

Benjamin has sketched this diagram to help work out $\frac{2}{5} \times \frac{2}{11}$

How can we calculate the product from this diagram?

Draw similar diagrams to find the product of:

$$\frac{2}{11} \times \frac{2}{5}$$

$$\frac{1}{2} \times \frac{3}{5}$$

$$\frac{2}{5} \times \frac{3}{4}$$

$$\frac{4}{10} \times \frac{6}{8}$$

Week 7 Session 4: Multiplying fractions II

Task 1

We can use the same ideas to multiply decimals and percentages.

This example shows

$$0.2 \times 0.3 = 0.06$$

or

“2 tenths times 3 tenths = 6 hundredths”

or

$$\frac{2}{10} \times \frac{3}{10} = \frac{6}{100}$$

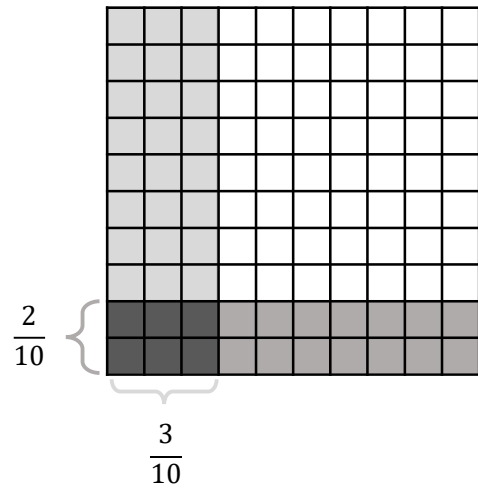

Write the calculations and answers that are shown in the following diagrams:

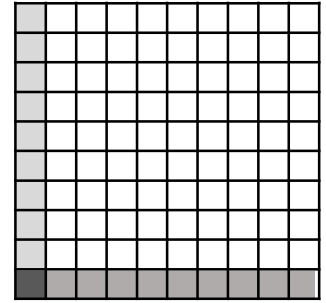
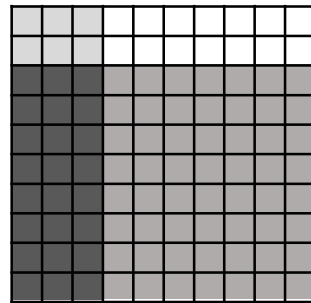
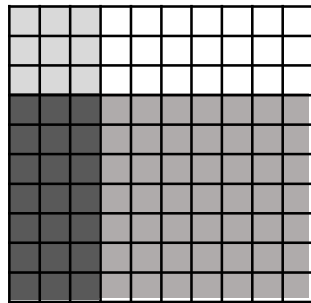
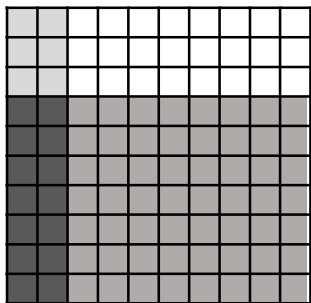

Task 2

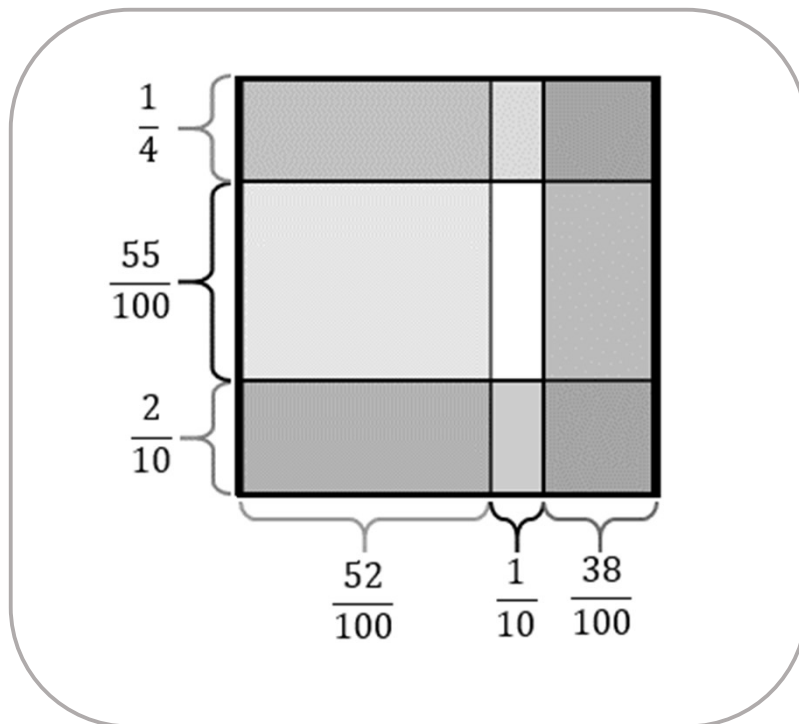

Find the area of the shaded rectangles, giving you answer as a decimal.

Week 8 Session 1: Dividing fractions by integers

Task 1

Two students are comparing methods for calculating $\frac{6}{7} \div 2$



$$\frac{6}{7} \div 2 = \frac{3}{7}$$



$$\frac{6}{7} \div 2 = \frac{6}{14}$$

There are half as many parts

Each part is half the size

These are equivalent!



Use their different methods to attempt these calculations:

$$\frac{6}{7} \div 3$$

$$\frac{4}{7} \div 2$$

$$\frac{4}{7} \div 3$$

Task 2

Organise these problems into groups.

Consider the method you would use to calculate them.

$$\frac{4}{5} \div 2$$

$$\frac{9}{10} \div 3$$

$$\frac{6}{11} \div 5$$

$$\frac{1}{2} \div 3$$

$$\frac{7}{8} \div 7$$

$$\frac{8}{15} \div 4$$

$$\frac{2}{11} \div 4$$

$$\frac{9}{20} \div 4$$

$$\frac{9}{10} \div 3 = \frac{3}{10}$$

$$\frac{1}{2} \div 3 = \frac{1}{6}$$



Week 8 Session 2: Modelling division by fractions I

Task 1

The student below has described the top bar model.

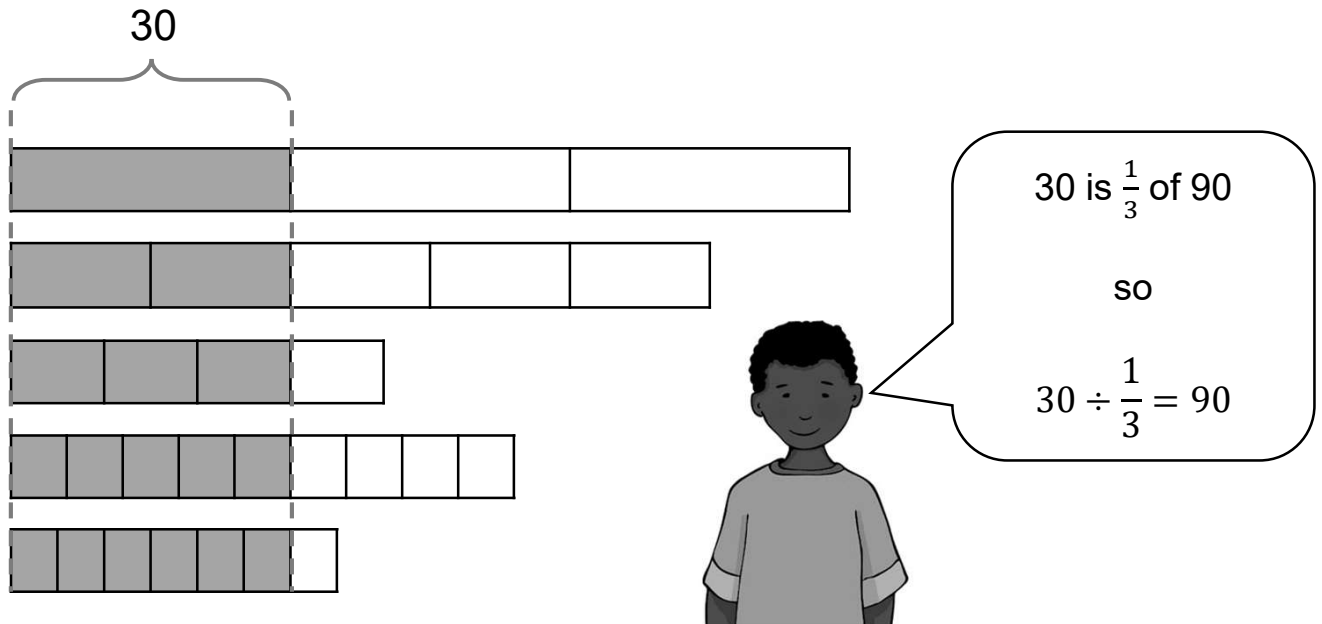

What similar statements can you make from this diagram?
Include the length of each bar in your division statements.

Task 2

How can we use the model below to find $\frac{2}{3} \div \frac{3}{4}$?

“ $\frac{2}{3}$ is $\frac{3}{4}$ of what?”

Write each of these problems in a similar form as above, and then find x

$\frac{5}{8} \div \frac{5}{6} = x$

$\frac{6}{7} \div \frac{2}{5} = x$

$\frac{1}{2} \div \frac{5}{7} = x$

$\frac{3}{4} \div \frac{2}{3} = x$

Week 8 Session 3: Modelling division by fractions II

Task 1

Look at Samantha's method for calculating $6 \div \frac{1}{4}$ on the left below.

$6 \div \frac{1}{4} = 24$

I know this because there $\frac{1}{4}$ goes into 6 wholes 24 times

What is $6 \div \frac{1}{2}$? What is $6 \div \frac{1}{3}$?
What is $6 \div \frac{1}{5}$?



What happens if we try other **unit fractions**?

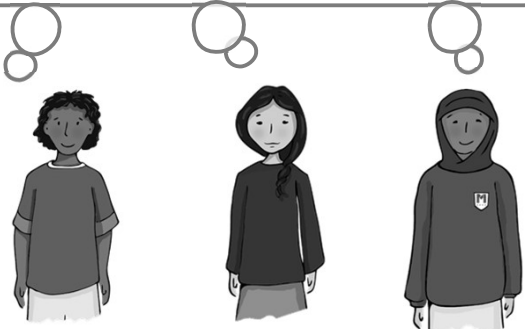

Answer the questions Samantha's friends are thinking about.
Can you spot a pattern?
Can you explain why this pattern happens?

Task 2

Samantha and her friends draw a diagram to support their answers:

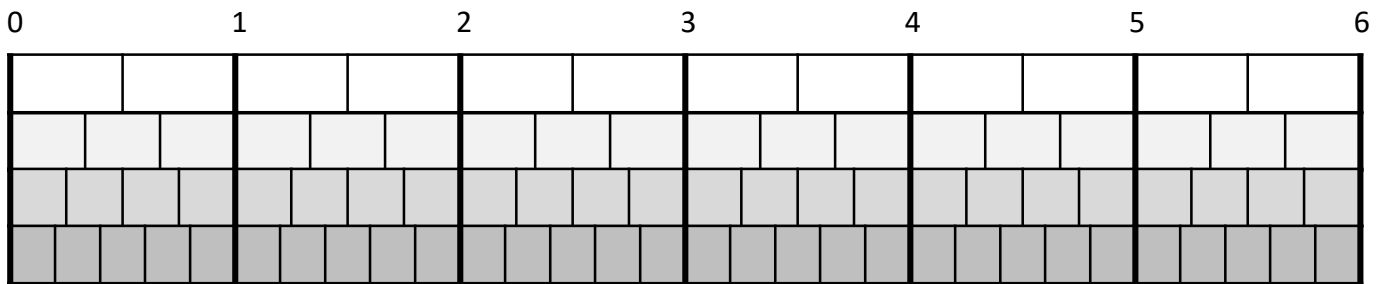

$6 \div \frac{1}{2} = 12$
 $6 \times 2 = 12$



$6 \div \frac{1}{3} = 18$
 $6 \times 3 = 18$



$6 \div \frac{1}{5} = 30$
 $6 \times 5 = 30$

Use their diagram to answer the following questions:

$6 \div \frac{2}{3}$

$6 \div \frac{3}{4}$

$6 \div \frac{2}{5}$

$6 \div \frac{3}{5}$

$6 \div \frac{6}{5}$

Week 8 Session 4: Fraction division in context

Task 1

Complete the function machines to match each method for calculating $6 \div \frac{2}{3}$



6 is $\frac{2}{3}$ of what?

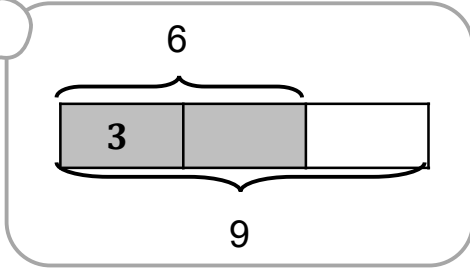

How many $\frac{2}{3}$ s make up 6?

I can work out how many $\frac{1}{3}$ s make up

6:

$$6 \times 3 = 18$$

$\frac{2}{3}$ is twice as big so only half as many

are needed:

$$18 \div 2 = 9$$

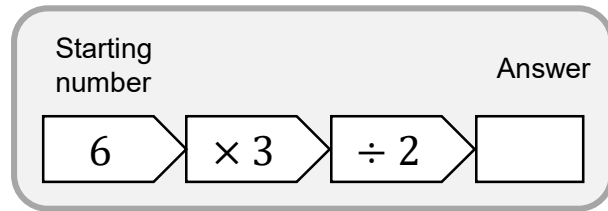
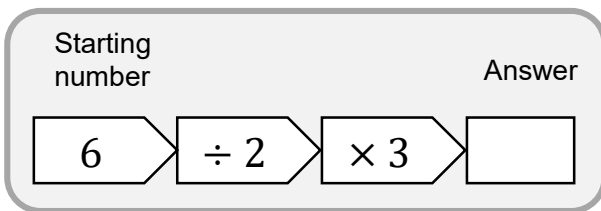

Draw two function machines for the following divisions:

$$15 \div \frac{3}{7}$$

$$\frac{4}{9} \div \frac{2}{5}$$

$$10 \div \frac{a}{b}$$

Task 2

Not to scale

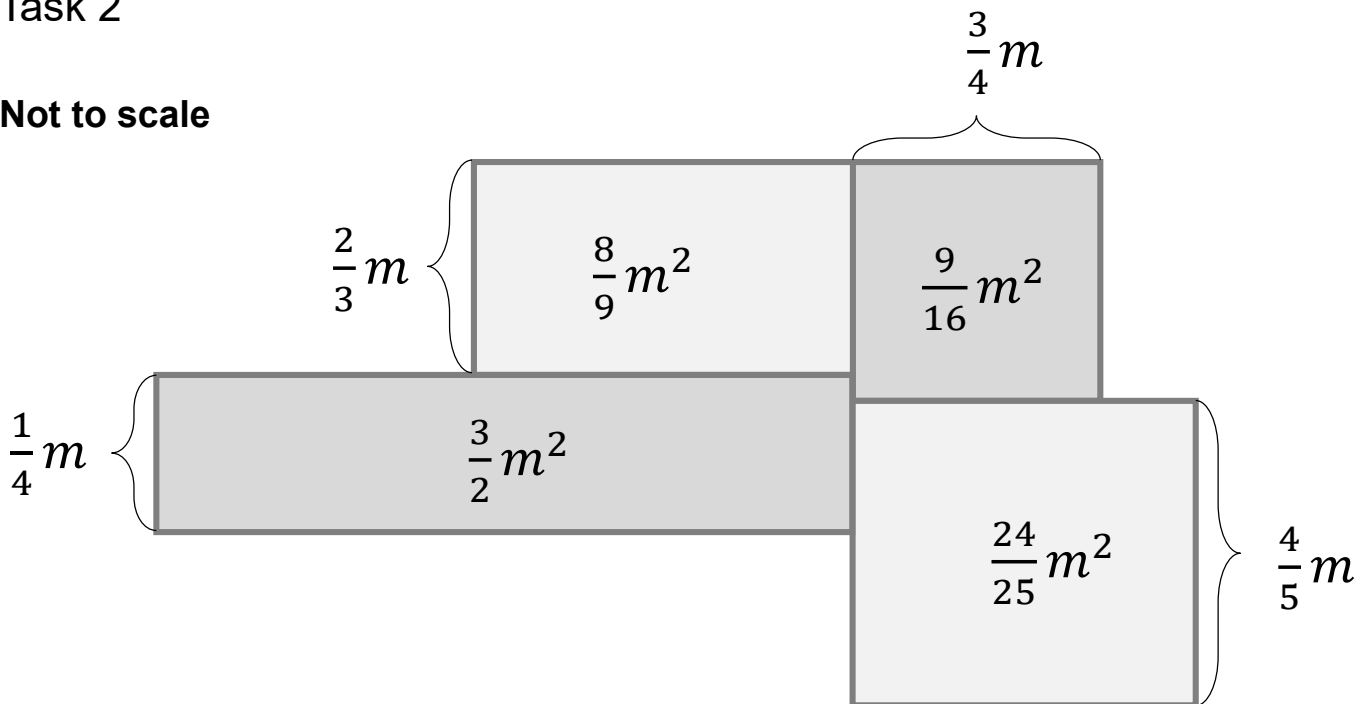

This compound shape has been constructed out of 4 rectangles. Which of the rectangles has the greatest perimeter? Which has the smallest perimeter

Week 9 Session 1: Adding and subtracting fractions

Task 1

Look at this student working to calculate $0.32 + 0.9$

Use a hundred square to help explain why they are **wrong**.

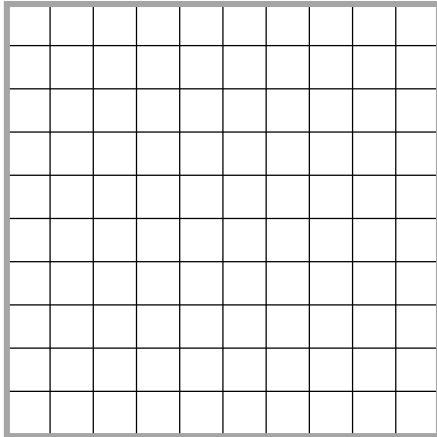

$0.32 + 0.9 = \frac{32}{100} + \frac{9}{10}$

Add numerators: $32 + 9 = 41$

$\frac{32}{100} + \frac{9}{10} = \frac{41}{100} = 0.41$

So:

$0.32 + 0.9 = 0.41$ ~~X~~

Task 2

Use the number cards to complete each inequality frames five different ways. You **may** repeat number cards.

Hint: You might like to try using the same denominator.

$$\frac{\square}{\square} - \frac{\square}{\square} > 0.5$$

$$\frac{\square}{\square} - \frac{\square}{\square} > 1$$

$$\frac{\square}{\square} + \frac{\square}{\square} < 0.5$$

1 2 3 4 5 6 7 8 9 10

12 15 20 25 30 50 75 80 100

Week 9 Session 2: Different denominators

Task 1

$$\begin{array}{|c|} \hline \square \\ \hline \square \\ \hline \end{array} + \begin{array}{|c|} \hline \square \\ \hline \square \\ \hline \end{array} = \begin{array}{|c|} \hline \square \\ \hline \square \\ \hline \end{array}$$

$$\begin{array}{|c|} \hline \square \\ \hline \square \\ \hline \end{array} - \begin{array}{|c|} \hline \square \\ \hline \square \\ \hline \end{array} = \begin{array}{|c|} \hline \square \\ \hline \square \\ \hline \end{array}$$

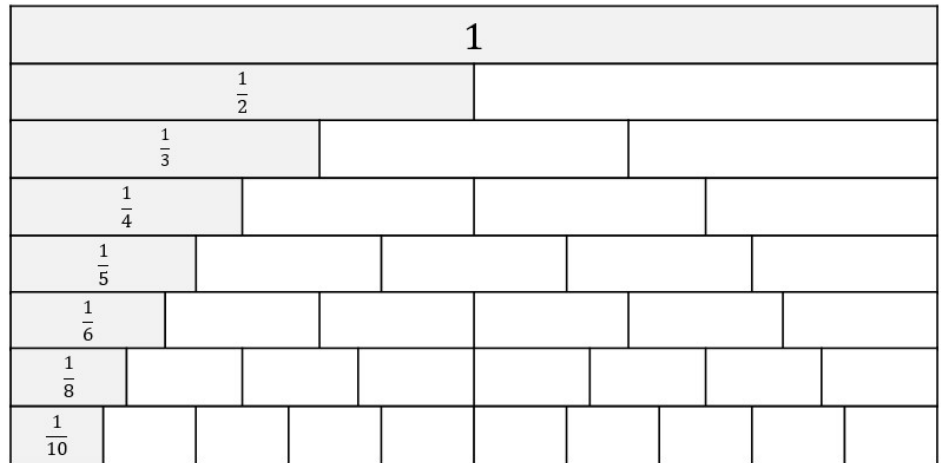

Using the frames to form different addition and subtraction calculations.
Can form calculations that have answers:

$$\frac{3}{4}$$

$$\frac{2}{3}$$

between $\frac{2}{3}$ and $\frac{3}{4}$

Task 2

Use the fraction wall from Task 1 or another representation to help decide if the statements below are true or false.

Be ready to explain your choice.

$$\frac{1}{2} + \frac{1}{3} < 1$$

$$\frac{1}{2} + \frac{1}{3} < \frac{1}{4} + \frac{1}{2}$$

$$\frac{7}{10} = 1 - \frac{2}{5}$$

$$\frac{1}{2} < \frac{2}{3} - \frac{1}{8}$$

$$\frac{3}{2} > \frac{3}{4} + \frac{5}{8}$$

$$\frac{1}{3} + \frac{3}{4} < \frac{2}{3} + \frac{1}{5}$$

How many ways can you complete the inequalities below?

$$2 - _ < \frac{7}{4}$$

$$1\frac{1}{2} > \frac{2}{3} + _$$

Week 9 Session 3: Using common denominators

Task 1

The whole grid represents 1.

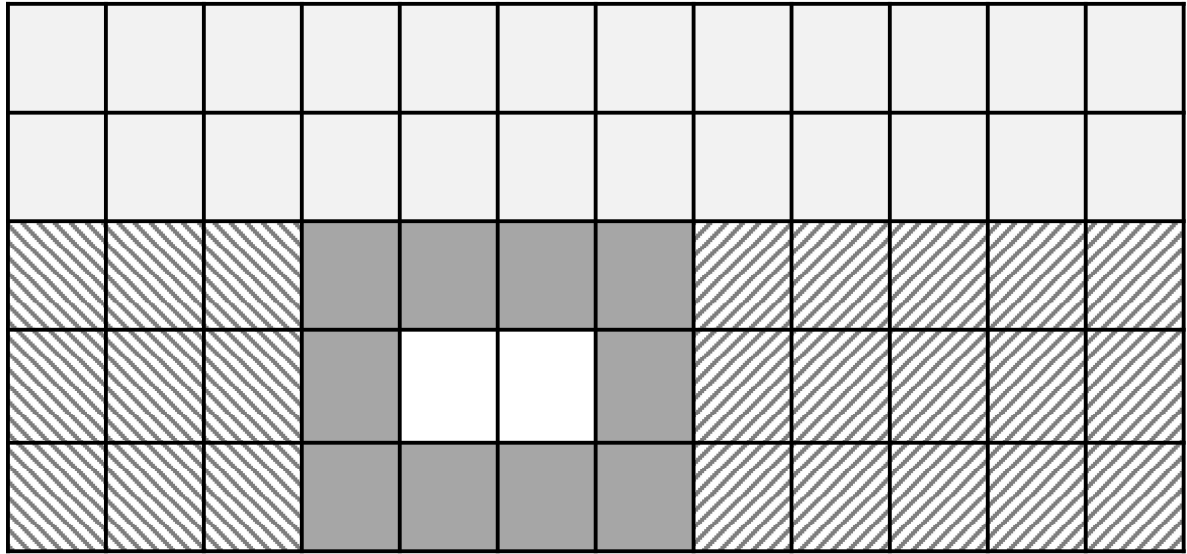

Identify the fractions shaded and write them in different ways including in their simplest form.

Task 2

Look at the fraction regions shaded in Task 1.

Form calculations by adding and subtracting those fractions.

What different answers can you make with these calculations?

Find ways of adding and subtracting these fraction regions to form the fractions below:

$$\frac{1}{12}$$

$$\frac{4}{5}$$

$$\frac{3}{4}$$

$$\frac{2}{15}$$

$$\frac{1}{2}$$

$$\frac{4}{15}$$

Week 9 Session 4: Distributivity

Task 1

How would you calculate the following?

Can you find a quick mental method?

$$\frac{2}{3} \times 7 + \frac{1}{3} \times 7$$

$$8 \times \frac{13}{12}$$

$$\frac{6}{7} \times 14 - \frac{5}{7} \times 14$$

$$\frac{3}{5} \times 19 - 4 \times \frac{3}{5}$$

Share the different ways you find of calculating these with someone else.

Which methods do you prefer? Why?

Task 2

How many equivalent calculations can you write?

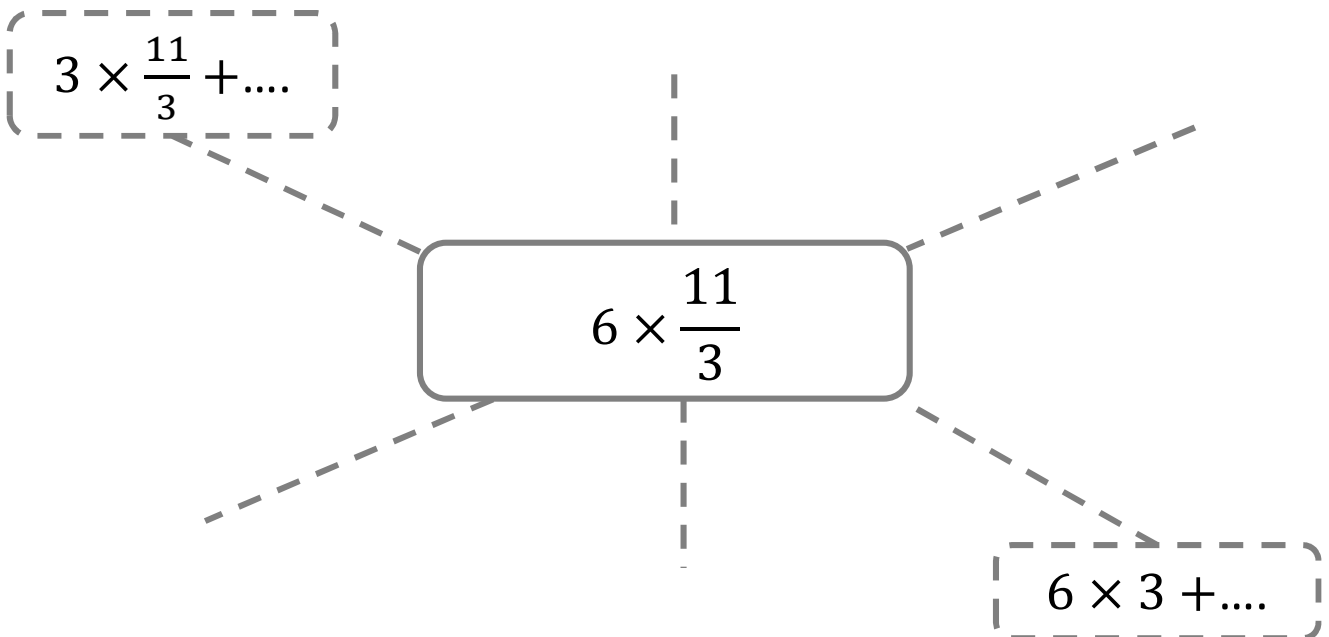

Week 10 Session 1: Percentage number line

Task 1

What values are represented on these number lines?

Give your answers as fractions, decimals and percentages.

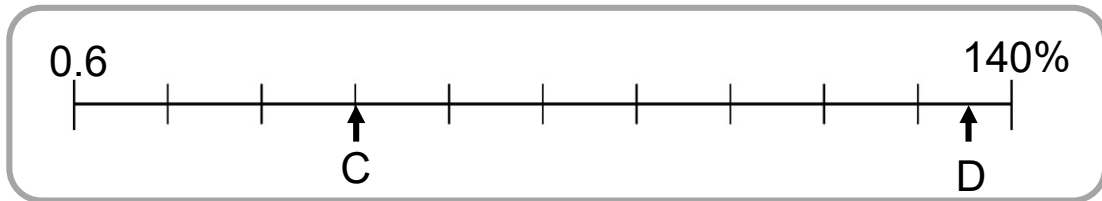
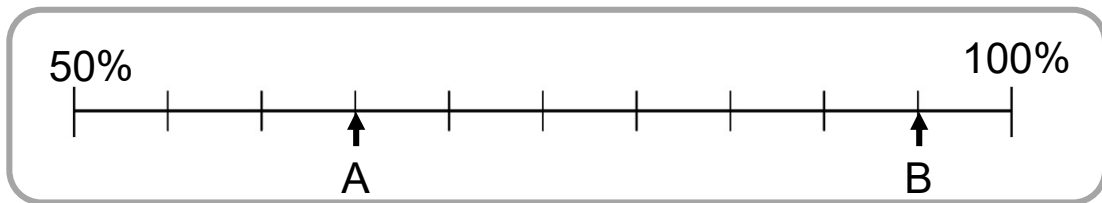

1

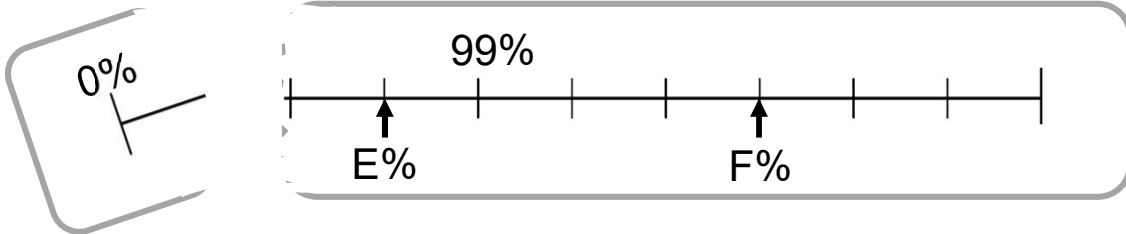

How many pairs of whole-number values can you find for E and F?

Task 2

Place these values on a number line between 0 and 1.

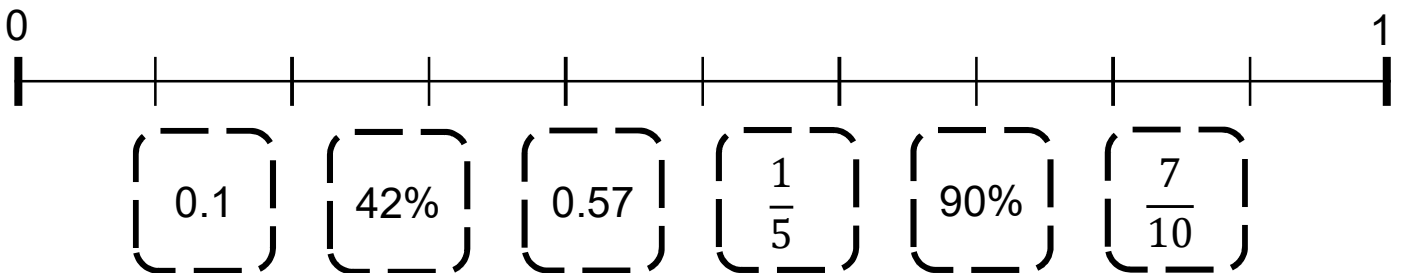

Now place these values on a number line between 0 and 2.

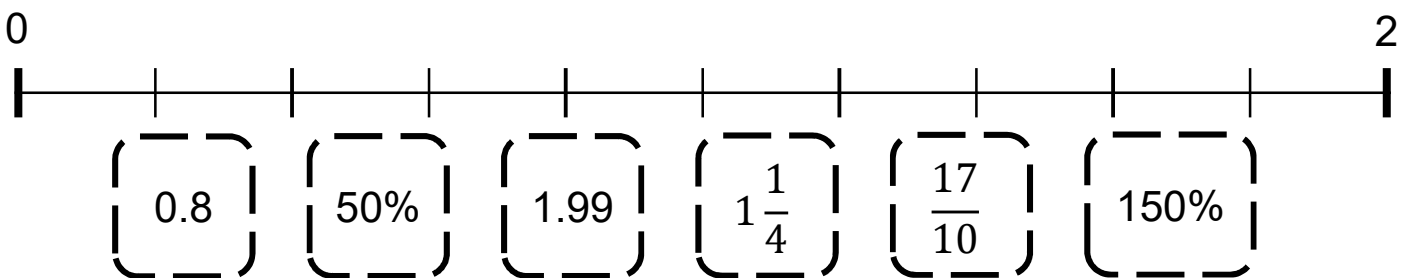

On each line, which pair of...

...adjacent values are closest together?

...adjacent values are furthest apart?

...any values have midpoint closest to the middle of the line?

Week 10 Session 2: Tenths, hundredths and thousandths

Task 1

We can represent decimal values and equivalent percentages using a place value table

Tens	Ones	Tenths	Hundredths	Thousandths		Percentage
	0	● 4			=	40%
	0	● 4	3		=	___ %
	0	● 4	6	3	=	___ %

Continue the table. You can use the digits 3, 4, or 6 at most once in the grey cells in each row, but you can use the digit 0 as many times as you like.

Which of your decimals can also be represented on this number line?

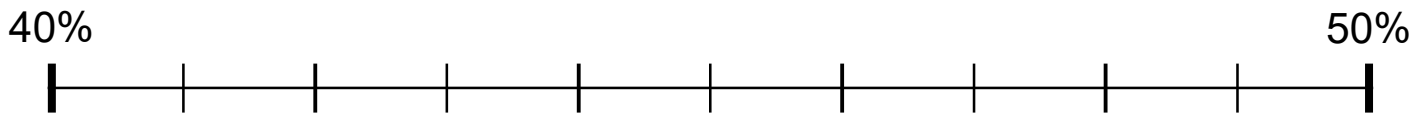

Task 2

How many ways can you complete this place value chart, using the four digit cards?

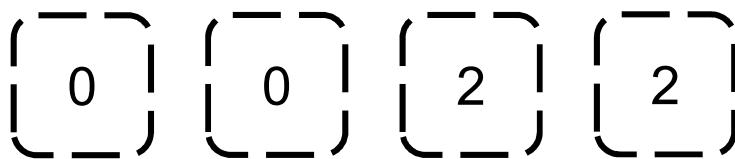

Ones	● Tenths	Hundredths	Thousandths		Percentage
	●			=	___ %

Write each decimal as a sum of fractions:

$$\left[\quad ? + \frac{?}{10} + \frac{?}{100} + \frac{?}{1000} = \underline{\quad} \quad \right]$$

Week 10 Session 3: Converting fractions and percentages

Task 1

Use the connections to complete these calculations.

$$100 \div 3 = \underline{\quad}, \text{ so } 1 \div 3 = \underline{\quad}, \text{ so } \frac{1}{3} = \underline{\quad} \%$$

$$100 \div 9 = \underline{\quad}, \text{ so } 1 \div 9 = \underline{\quad}, \text{ so } \frac{1}{9} = \underline{\quad} \%$$

How many ways can you complete these number frames?

$$\frac{\boxed{?}}{9} = \boxed{\underline{\quad} \%}$$

$$\frac{\boxed{?}}{6} = \boxed{\underline{\quad} \%}$$

Task 2

Continue each sequence for two more terms.

Express the fractions in each sequence as their equivalent percentages.

$$\frac{1}{10}, \frac{5}{10}, \frac{9}{10}, \frac{?}{?}, \frac{?}{?}$$

$$\frac{1}{5}, \frac{4}{5}, \frac{7}{5}, \frac{?}{?}, \frac{?}{?}$$

$$\frac{3}{5}, \frac{3}{4}, \frac{9}{10}, \frac{?}{?}, \frac{?}{?}$$

$$\frac{3}{1000}, \frac{3}{100}, \frac{3}{10}, \frac{?}{?}, \frac{?}{?}$$

$$\frac{3}{4}, \frac{6}{40}, \frac{12}{400}, \frac{?}{?}, \frac{?}{?}$$

Week 10 Session 4: Percentages of quantities

Task 1

We can use a bar model to calculate percentages of quantities.

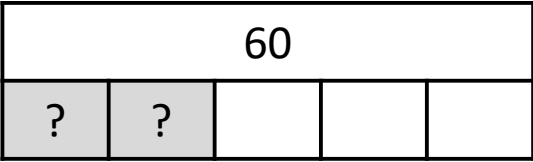
a) 40% of 60 = ___  because $\frac{40}{100} = \frac{?}{?}$

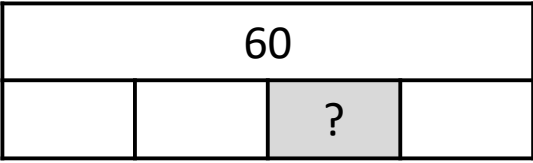
a) 25% of 60 = ___  because $\frac{25}{100} = \frac{?}{?}$

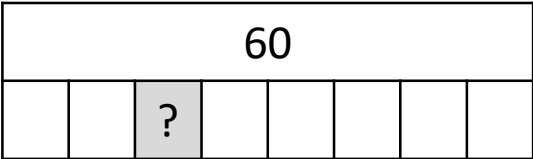
c) ___ % of 60 = ___  because $\frac{1}{?} = \frac{?}{100}$

Now complete similar bar models and equality statements for

- d) 33.3% of 60
- e) a percentage > 100% of 60

Task 2

Match up the pairs of calculations that have the same value. There will be one left over. Suggest some possible calculations that it could be paired with.

60% of 80	25% of 80	$\frac{3}{5}$ of 80
37.5% of 80	$\frac{1}{4}$ of 240	75% of 60
75% of 80	250% of 8	$33\frac{1}{3}$ % of 90